

THE GANG-NAIL TRUSS SYSTEM

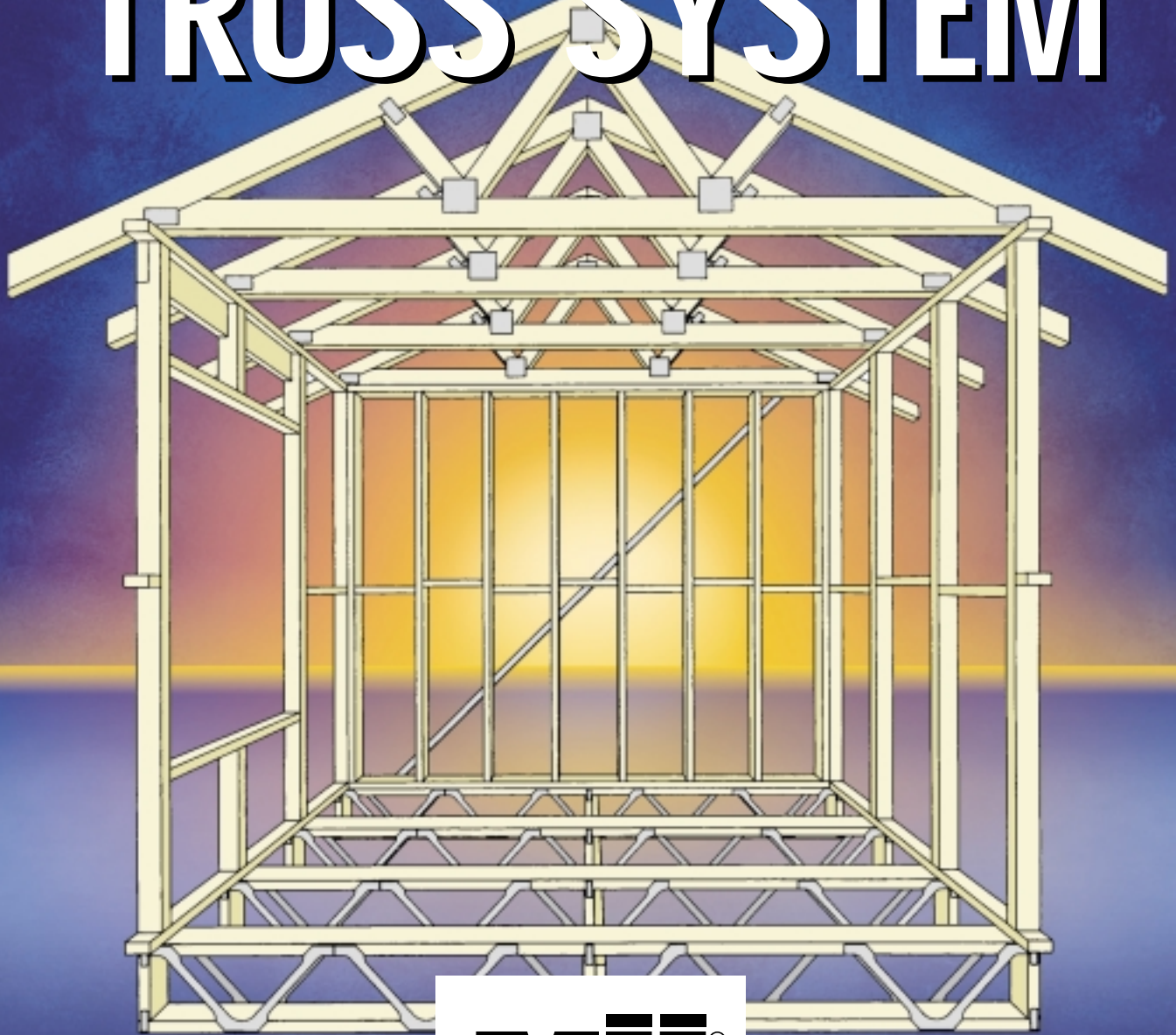

creating the **advantage**

To find out more about MiTek's products & systems, call your local state office or visit our web site: www.mitek.com.au
VIC (03) 8795 8888 NSW (02) 9609 8700 QLD (07) 3268 1666 SA (08) 8234 1326 WA (08) 9411 2845 NZ (09) 274 7109 MALAYSIA (603) 3176 7473

HOME OF GANG-NAIL BUILDING SYSTEMS

INDEX

Introduction	4
Advantages of Roof Trusses	
Truss Terminology	6
Trusses How They Work	10
Basic Truss Mechanics	12
Camber	
Truss Analysis and Member Design	
Gang-Nail Connectors - How They Work	16
Performance criteria for Gang-Nail Connectors	
Engineering Data	
Roof Truss System	17
Advantages of Roof Trusses	
Design Flexibility	
Strength	
Project Management	
Building Permits	
Roof Layouts	
Gable Roof	
Hip Roof	
Dutch Hip Roof	
Bell Roof	
L & T Shaped Roofs	
Manufacturing Specification	23
Design	
Connectors	
Timber	
Fabrication	
Ordering Trusses	26
Transport, Storage & Lifting	27
Transport and Job Storage	
Lifting	
Supporting Structure	28
Installation	28
Bracing	29
PosiSTRUT	30
ConstructaBEAM System	33

INTRODUCTION

MiTek Australia Ltd revolutionised house construction in Australia when it introduced the use of Gang-Nail multi-tooth connectors for the manufacture of prefabricated timber trusses in the 1960's.

Before Gang-Nail trusses were available, all house carpentry was carried out on site. Timber has always been a "craft" material with scantling sizes and joints based on established carpentry practice. The post-war building boom demanded a more efficient use of materials and labour.

The Gang-Nail System of roof trusses was the first major component of a house to be prefabricated. Wall frames followed, and now floor frames in the form of PosiSTRUT® trusses are also manufactured off-site. The prefabrication of components for houses enables quicker construction schedules, better quality control and reduces construction costs.

The Gang-Nail System allows the principles of structural engineering to be applied to house building. The science of Timber Engineering has also come of age since the introduction of the Gang-Nail System.

The Gang-Nail Truss System is based on the Gang-Nail timber connector which is a steel plate with multiple spikes or nails projecting from one face. The connectors are pressed into the surface of the timber using large hydraulic presses, causing the nails to embed in the timber. Timber elements can be joined together with strength and ease to make trusses and other structural timber components.



The ease of installation and effectiveness as a timber connector make Gang-Nail connectors ideal for the prefabrication industry where speed and reliability are paramount. The name "Gang-Nail truss" has now become synonymous with quality prefabricated timber roof truss.

As the benefits of lightweight timber roof trusses became apparent, their use spread to industrial and commercial projects as a viable alternative to traditional steel structures.

The Gang-Nail System has also spawned a whole range of ancillary connectors for timber, such as Trip-L-Grips, Joist Hangers and Tylok plates, as well as built-up solid members such as the Gang-Nail ConstructaBEAM Floor Joists, Rafters and Purlins.

MiTek Australia Ltd does not actually manufacture trusses. The company manufactures the steel connector plates and ancillary items which are supplied to a select national network of independent, licensed truss fabricators. Each of these companies has been chosen as a MiTek licensee because of their high standards of management and for their professionalism within the building materials industry.

The supply of connectors is only a small part of MiTek Australia Ltd's activities. It is the technical support provided to MiTek's licensees which is the true strength of the Gang-Nail System.

Technical support starts with the state-of-the-art connector plate design and includes MiTek's commitment to research and development both within Australia and internationally.

A rigid program of quality control is applied during manufacture. This ensures that the steel used in the manufacture, and the finished product, meets the highest standards. In recognition of this, MiTek Australia Ltd. at Lyndhurst, Victoria, has been certified as a Quality Endorsed Company to ISO 9001.



MiTek Australia Ltd. has an engineering design office to assist MiTek licensed fabricators with truss designs, and to provide engineering details on unusual roofing designs. Over the years, computer programs developed for this truss design service have evolved into sophisticated programs, which MiTek licensed fabricators can use themselves to prepare quotations and to design and detail roof trusses and wall frames. These programs – MiTek20/20, DataTRUSS®, RoofFAB and Panel – also provide the MiTek licensed fabricator with a means of stock control, production scheduling and performance overview.

MiTek Australia Ltd. also provides training to its licensed fabricator staff in all aspects of truss fabrication and truss plant operation.

Today it is this innovative and extensive technical support which maintains MiTek Australia Ltd's leadership in roof truss and associated industries.

Advantages of Gang-Nail Roof and Floor Trusses

Prefabricated timber roof and floor trusses offer greater design freedom, guaranteed strength and improved project cost control.

Almost any shape of truss is practicable and economical. Intricate roof surfaces and ceiling profiles can be achieved, and trusses can be designed for a variety of roof loadings – ranging from cyclonic winds to snow loads – with spans up to 30 metres. Visually, the bold patterns of exposed structural truss elements can be used to architectural advantage.

Gang-Nail trusses meet the Australian Standards for Timber Structures, Dead loads, Live loads and Wind loads. The timber specified for each truss element is described by both size and Stress Grade. Gang-Nail connector plate sizes specified for each truss joint are determined by the forces being transmitted and the nail-holding capacity of the type of timber in the truss.

Prefabricated trusses are cost-effective – trusses use the inherent strength of timber efficiently and factory automation brings the economies of scale to even the shortest production run. Site labour and supervision are greatly reduced and the effects of the weather on construction programs are minimised.

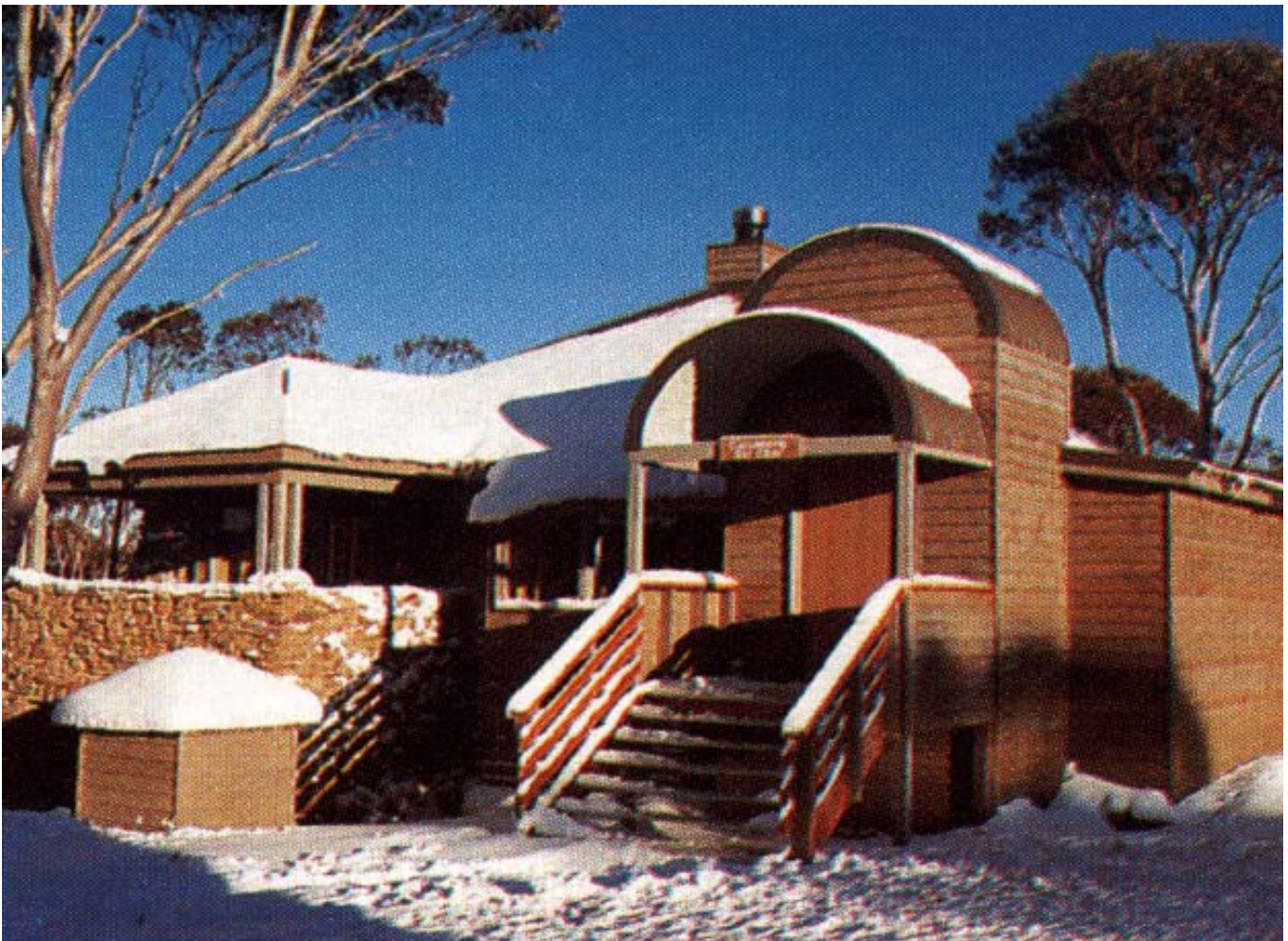

TRUSS TERMINOLOGY

Technical terms used in the truss industry may not be familiar. Some of the more common are listed below and are illustrated on pages 8 & 9.

Apex:

The highest point on a truss.

Barge:

Trim along the edge of roofing at a gable end. Slopes at roof pitch. It is fixed to ends of battens, purlins or verge rafters.

Batten:

Roofing battens or ceiling battens. Usually timber members fixed at right angles to the truss chords to support roof tiles or ceiling material. Also provides lateral restraint to the truss.

Bearing/Support point:

Point at which the truss is supported. A truss must have two or more supports located at truss panel points.

Bottom chord:

Truss member forming bottom edge of truss.

Butt joint Splice:

End-to-end joint between two pieces of timber.

Camber:

Vertical displacement built into a truss to compensate for the downward movement expected when truss is fully loaded.

Cantilever:

That part of a truss that projects beyond an external main support, not including top chord extensions or overhangs.

Chord:

The truss members forming the top and bottom edges of the truss.

Clear span:

Horizontal distance between inner edges of supports.

Concentrated load:

A load applied at a specific position. e.g. load applied by an intersecting truss.

Connector:

Light gauge steel plates with teeth projecting from one face. When pressed into intersecting timber members the plate connects the members in a rigid joint.

Creep:

Movement resulting from long-term application of load to a timber member.

Cut-off:

Description of a truss based on standard shape but which is cut-off short of its full span.

Dead Load:

Permanent loads due to the weight of materials and truss self-weight.

Deflection:

Vertical and horizontal movement in a truss due to the applied load.

Design Loads:

The various loads that a truss is designed to support.

Distributed Load:

Loads spread evenly along truss member.

Fascia:

Trim along the edge of the eaves.

Gable Truss:

Standard triangular shaped truss.

Girder Truss:

Truss designed to support one or more trusses.

Heel Joint:

The joint on a truss where the top and bottom chords meet.

Heel Point:

The position on a truss where the bottom edge of the bottom chord meets the top chord. Used for setting up production jigs

Hip:

Intersection of two roof surfaces over an external corner of a building.

Hip Roof:

Roof constructed with rafters or trusses pitched over all perimeter walls.

Joint Strength Group:

Classification of timber according to its ability to perform with fasteners such as bolts, nails and Gang-Nail connectors. The grouping depends on timber species and moisture content.

King Post:

Vertical web at the centre of a gable truss, or the vertical web at the end of a half gable truss.

Lateral Brace:

Bracing restraint applied at right angles to web or chord to prevent buckling.

Longitudinal Tie:

Bracing restraint applied at right angles to web or chord to prevent buckling.

Live Load:

Temporary load due to traffic, construction, maintenance etc.

Overall Length:

Length of truss excluding overhangs.

Overhang:

Extension of top chord beyond support. Provision of eaves on gable trusses.

Nominal Span:

The horizontal distance between supports of a truss.

Panel-point:

The point where several truss members meet to form a joint.

Panel-point Splice:

Splice joint in a chord coinciding with web intersection.

Pitch:

Angular slope of truss chord measured in degrees.

Purlin:

Roofing purlins. Usually timber members fixed at right angles to the truss chords to support roof sheeting. Also provides lateral restraint to truss. Similar to battens except more widely spaced.

Rafter:

A roof member supporting roofing battens or roofing purlins in conventional construction. Rafters employ only the bending strength of the timber. A roof truss may also be called a trussed rafter.

Ridge:

The highest point on a gable roof.

Span:

The horizontal distance between the outer edges of the truss supports.

Span Carried:

The span of standard trusses that are supported by a girder truss

Stress Grade:

Strength classification of timber. Based on species, seasoning and frequency of defects such as knots and sloping grain. Alternatively based on actual mechanical testing of each piece.

Station:

The position of a truss measured from the outside face of the end wall. Usually used to describe the position of truncated Girder and Standard trusses in a Hip End.

Strut:

Structural member subject to axial compression. In the context of truss, this term is used for compression webs.

Symmetrical Truss:

Truss with symmetrical configuration and design loading.

Top Chord:

Truss member forming top edge of truss.

Truss:

Trussed rafter. Triangulated, self-supporting framework of chords and webs that supports applied loads by a combination of the bending strength of the chords and the axial compressive and tensile strength of the chords and webs.

Valley:

Intersection of two roof surfaces over an internal corner of a building.

Verge:

Roof overhang at a gable-end.

Verge Rafter:

Rafter projecting from gable end to support verge.

Waling Plate:

Timber member bolted to the face of a truss to support intersecting rafters or trusses. May also be used to support intersecting battens or purlins.

Web:

The internal members of a truss. Usually only subject to axial loads due to truss action.

Wind Load:

Load applied to the roof by the wind.

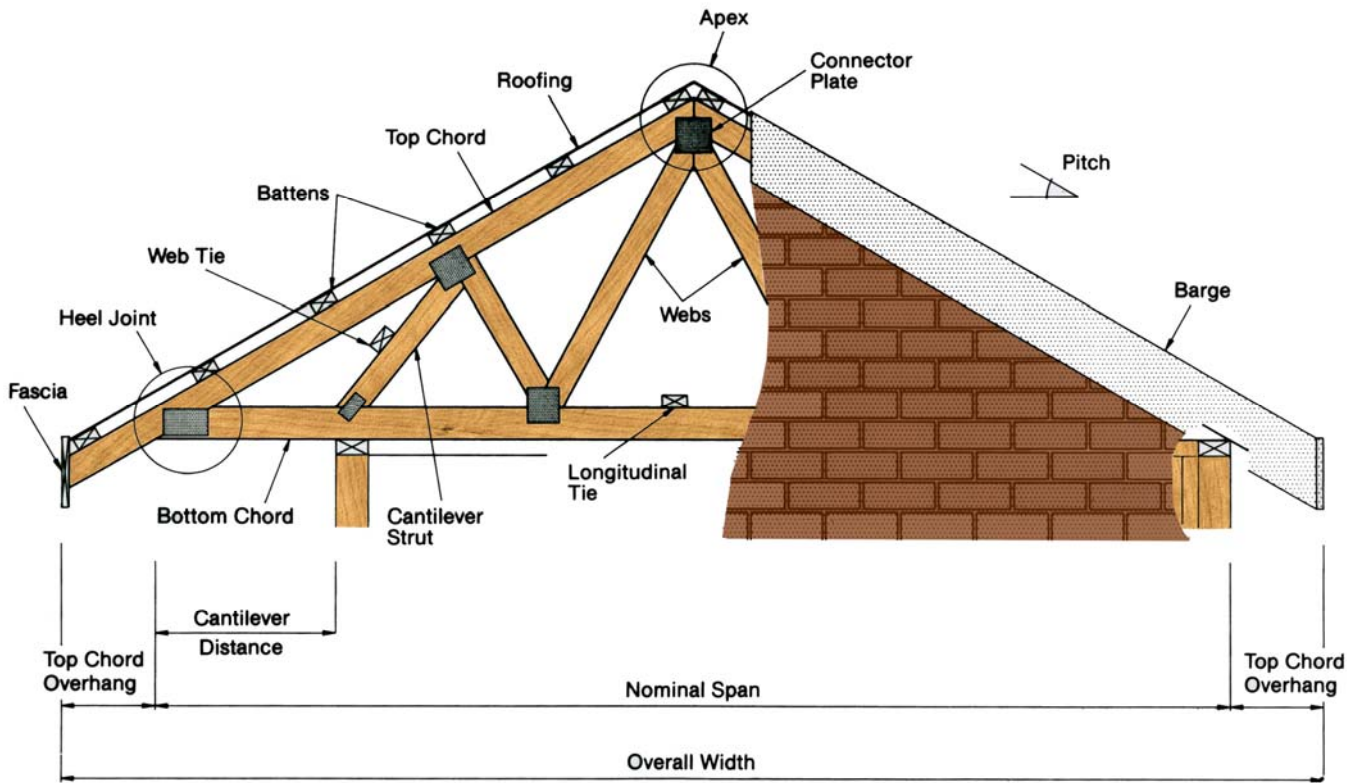

GABLE END

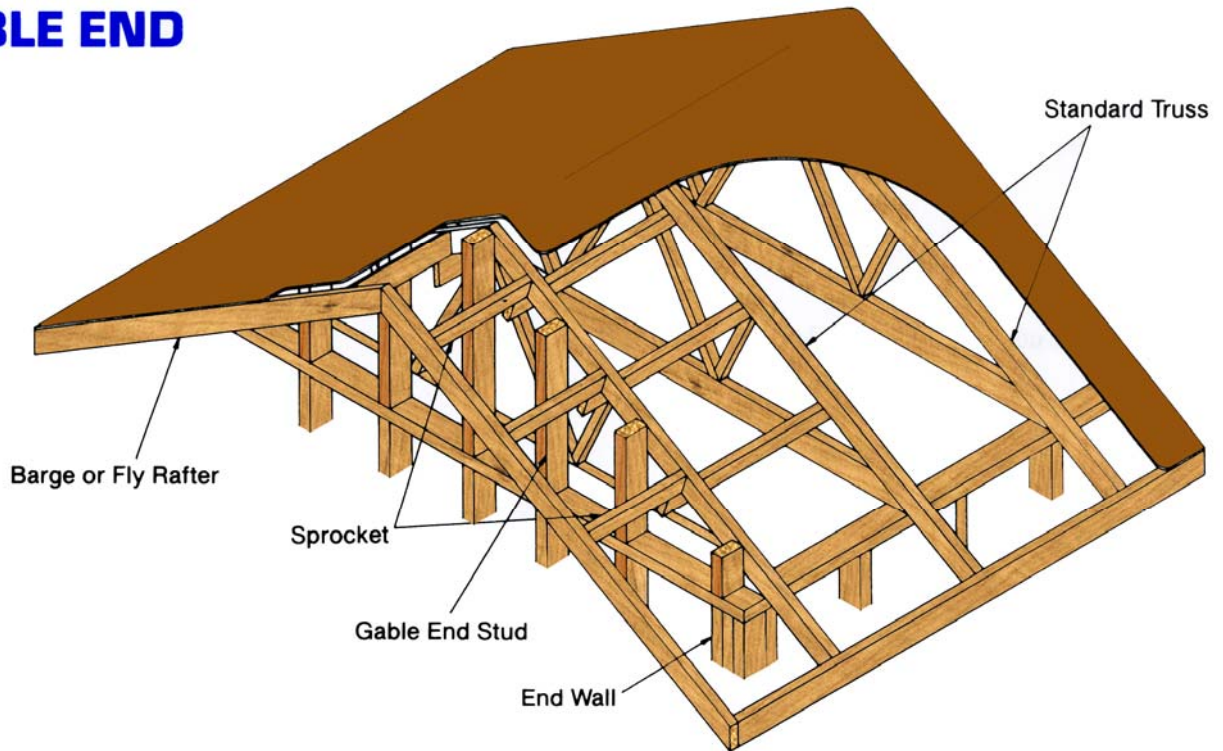

DUTCH HIP END

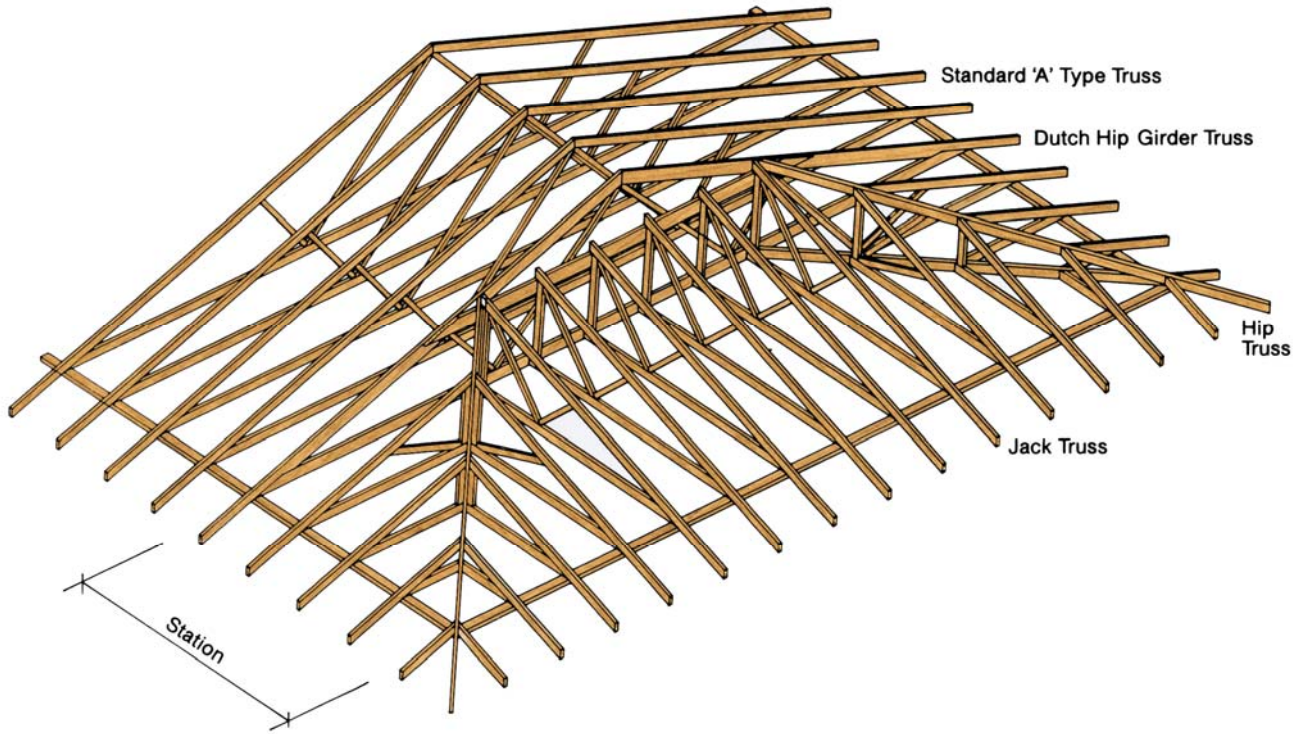

HIP END

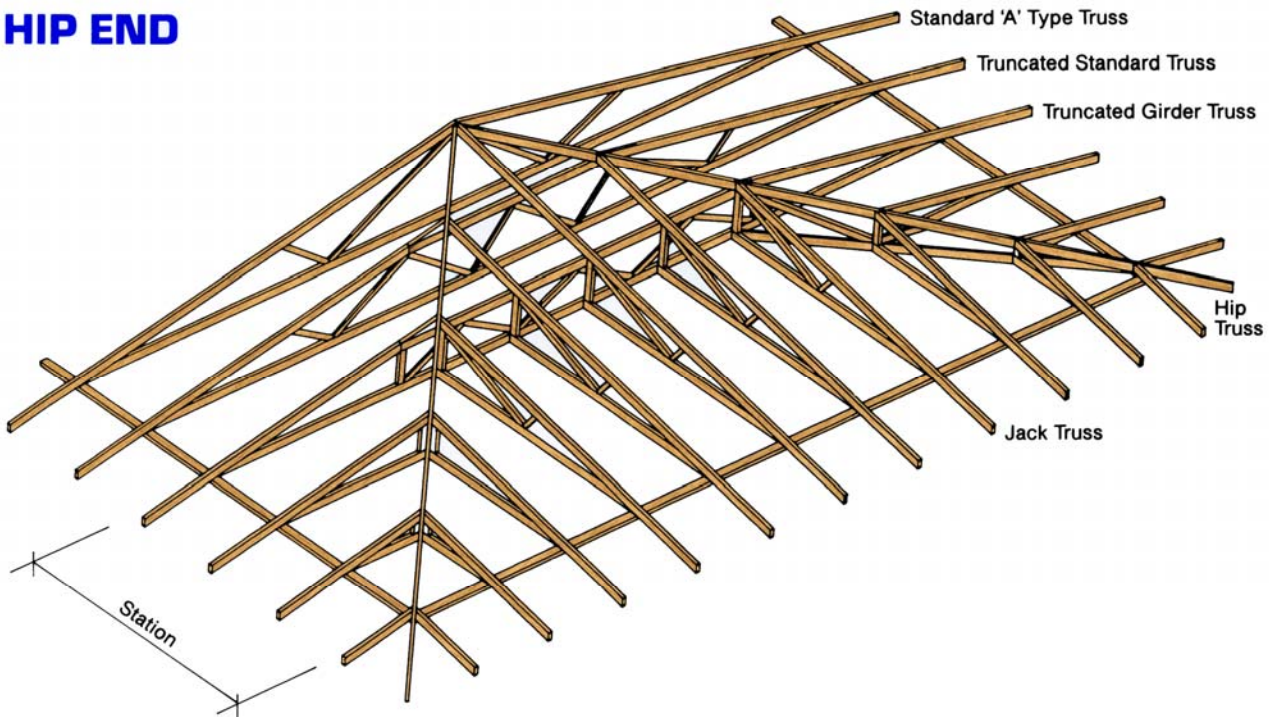

TRUSSES - HOW THEY WORK

In the evolution of building there have been two great developments since man first used timber or stone to provide himself with shelter. These materials were first used as simple beams. The Romans are credited with the invention of the arch, and the truss was developed in Europe during the middle ages.

A beam supports loads due to its bending strength. This is the way simple members such as rafters, battens, purlins, lintels and bressummers work. The top edge of a beam is normally in compression and the bottom edge in tension. These stresses reach a maximum near the middle of the beam's span and for every doubling of span the strength of the beam must increase four times. Beams also tend to sag when loaded and sag is even more sensitive to increases in span than the requirement for increased strength.

The Romans found that if they leant stones against one-another in the shape of an arch, they could span greater distances than by using the stone as simple lintels or beams. In an arch the stones are in compression. The arch will perform as long as the supports or buttresses at each end of the arch provide restraint, and do not spread apart. Timber beams can also be propped against one-another to form arches. The timber members will be in compression and will also act as simple beams.

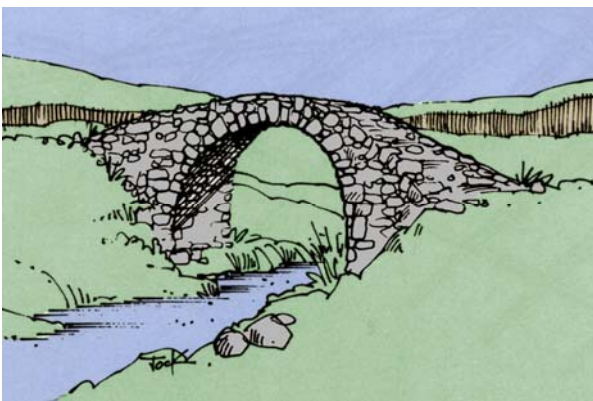

Roman Arch Bridge

To turn the arch into a truss, all that is required is to provide a tie between the two buttresses to stop them from being pushed apart by the arch. The arch, beam, tie combinations is self-supporting – we call this structure a truss.

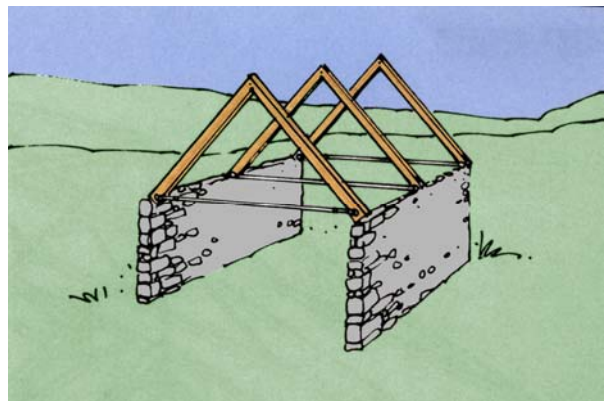

Timber Arch

Gang-Nail trusses are based on these simple structures. All the truss members are timber, and the joints between the members are formed using Gang-Nail connector plates.

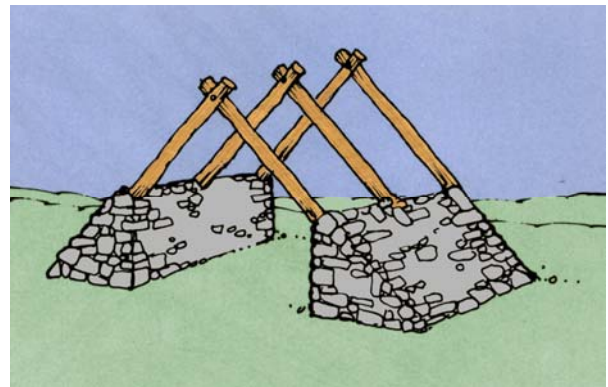

Single Truss with Arched Rafter and Tie

The characteristic appearance of a truss is a framework formed by many small triangles. A triangle is a naturally stable shape, compared with say a rectangular framework which can be deformed unless its joints are rigid or it is braced from corner to corner. Such a brace would, of course, convert a rectangle into two connected triangles on a truss. The members forming the perimeter of a truss – the chords – usually act as beams as well as ties or struts. The shorter the distance between truss joints, the smaller the chord section required.

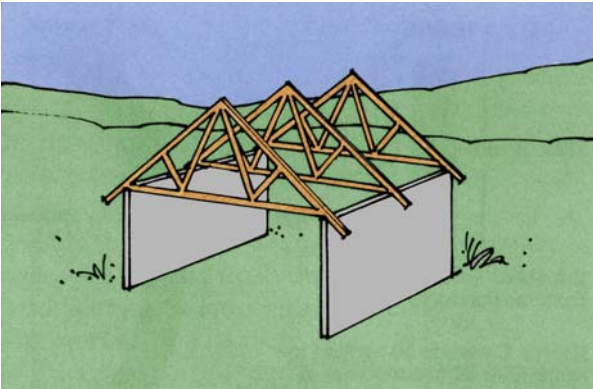

Common "A" Type Gang-Nail Truss

However, the more joints there are in the truss, the more expensive it is to fabricate. The designer of a truss can choose the arrangement of the chords and webs and must balance structural efficiency against manufacturing efficiency in supporting the applied loads.

BASIC TRUSS MECHANICS

All trusses in a roof structure are designed for the worst possible combination of dead, live and wind loads. The individual truss members are designed to restrain the corresponding forces i.e., tension or compression, or a combination of bending with either the tension or compression force.

Tension (pulling). With this type of force the member being pulled or subjected to a tension force is said to be "in tension". The ability of a member to restrain tension forces depends on the material strength of the member and its cross-sectional area.

Figure 1

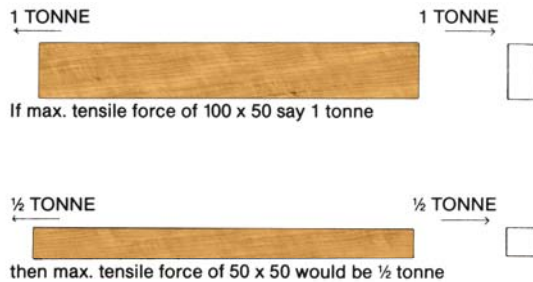

The example shows that if the cross-sectional area of a member is doubled, the ability of that member to restrain the tension forces is also doubled.

Compression (pushing). When a structural member is subjected to this type of force it is sometimes referred to as a column. Unlike a tension member, the ability of a column to restrain compression forces is not simply a function of the cross-sectional area, but a combination of the material strength, the column length and the cross-sectional shape of the column.

If one tonne is the maximum compression force that can be supported by a piece of 100 x 38 mm timber, 1200 mm long without buckling, then the same force applied to a piece of 100 x 38 mm timber, but twice as long, would certainly cause it to buckle and possibly collapse.

Figure 2

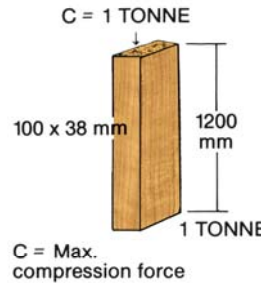
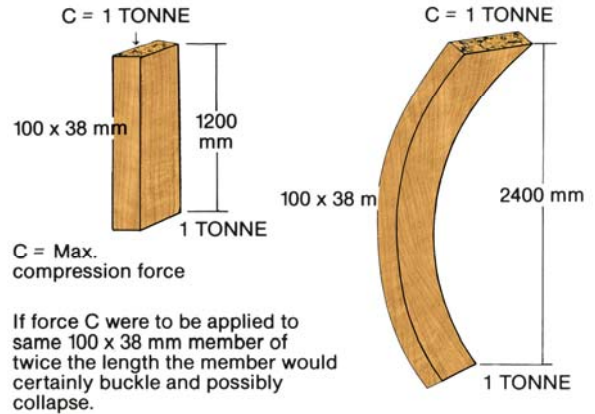
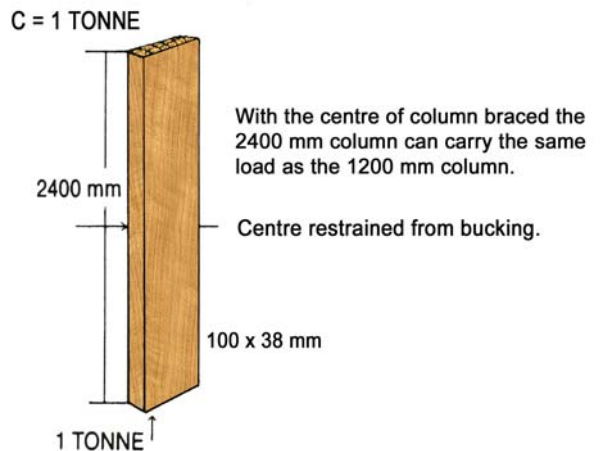

Figure 3



However, if we rigidly support the 2400 mm long column in the previous example at the centre, it would then be capable of withstanding the one tonne force.

Figure 4



Where this rigid support is applied to a web member, it is called a web tie, which is used in conjunction with bracing. (See Figure 5A)

Figure 5a

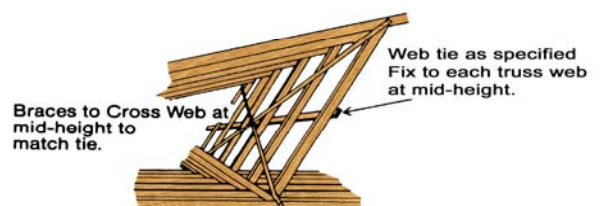

Battens with bracing from the rigid supports are needed to restrain the truss chords from buckling sideways. (See Figure 5b).

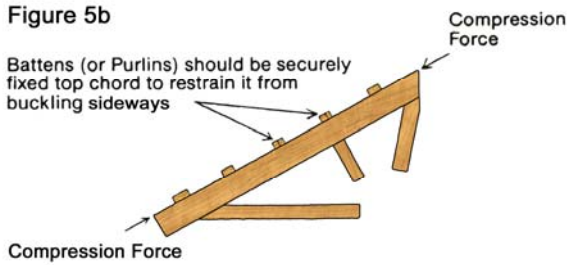

The strength of a column is also dependent on the cross-sectional shape of a column. The squarer or more symmetrical the shape, the stronger the

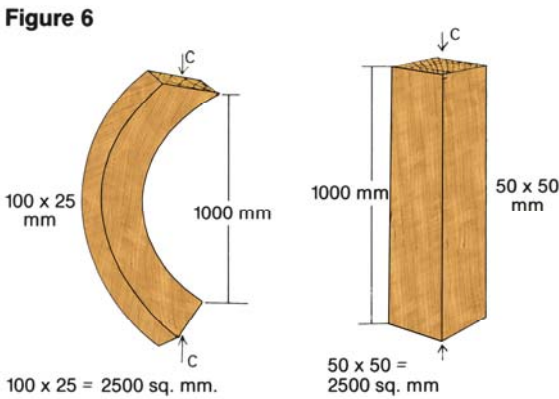

column, given that the cross-sectional area is the same.

In the example of 100 x 25 member having a cross sectional area of 2500 mm is not as strong in compression as a 50 x 50 member, provided that the other factors of length and material strength are equal.

Figure 7

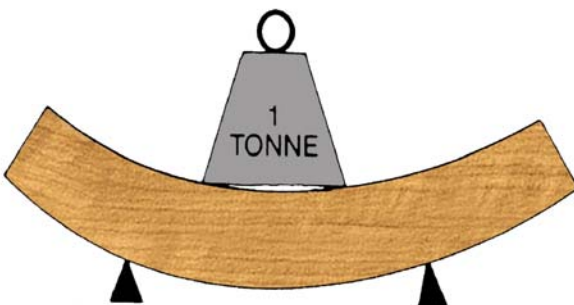

Bending force, or more correctly bending moment, is the result of a force applied to a cantilever, for example: a diving board, or to a simple beam.

The load carrying capacity of a beam is dependent upon the strength of the material and also the cross-sectional shape of the beam. In the case of the beam, unlike the column, the deeper section having the same cross-sectional area will be the stronger member in bending. Beams subject to bending moments also require lateral restraints, as with columns.

The deeper the beam the greater number of restraints required.

Figure 8

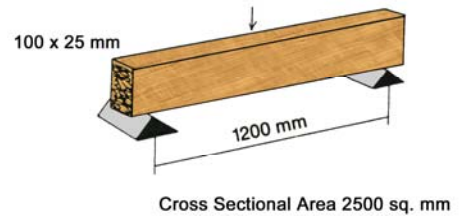

Deeper sections having the same cross sectional area are stronger in bending.

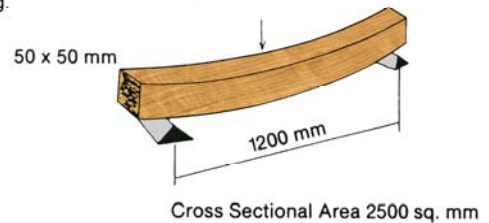

Forces in Members.

In many common types of trusses it is possible to identify the type of force which is in any particular member without undertaking any calculations.

The example in figure 9 is a common 'A' type gable truss with a uniformly distributed load along the top and bottom chords. This is due to the transfer of the load of the tiles through the tile battens and the ceiling load through the ceiling battens.

This means that the chords are subjected to bending forces as well as compression and tension forces. This loading arrangement would result in the top chord restraining compression plus bending forces. The short web is in compression and the long web is in tension. The geometry of both 'A' & 'B' type gable trusses is arranged so that under normal conditions, the longer webs are in tension and the shorter webs in compression. This is done to economise on the size of the timber required for the compression webs.

Figure 9

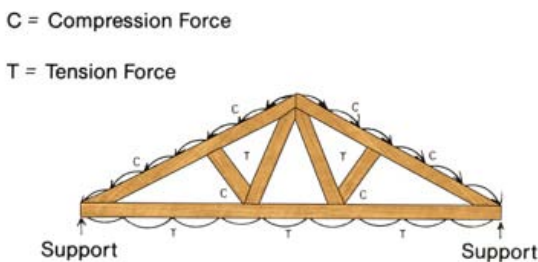

Deflection.

Wherever a member is subjected to a tension, compression or bending force (bending moment), the member is deformed by the force, irrespective of how strong the material is or how large the section. The amount of deformation does, however, depend on material strength and the size and shape of the section.

In Figure 10a it can be seen that the Oregon beam would deflect 32 mm soon after the one tonne point load is applied at a mid-span. If this load is maintained, the deflection may gradually increase to three times the initial deflection after a period of 20 to 24 months. This increase in deflection, with time, without increase in load, is called "creep". This characteristic is significant with timber, but can be ignored in other structural materials like steel.

Figure 10a

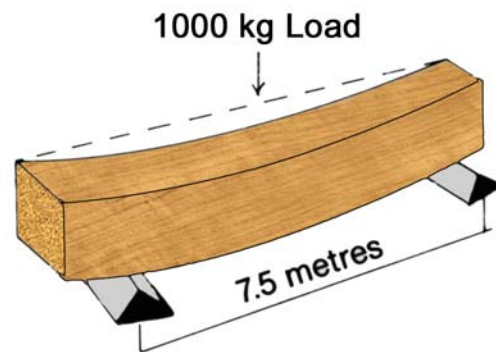

350 x 75 OREGON BEAM

If the same load is applied to a steel universal beam (see Figure 10b), the spontaneous deflection is approximately 1 mm. The long term deflection will also be 1 mm.

Figure 10b

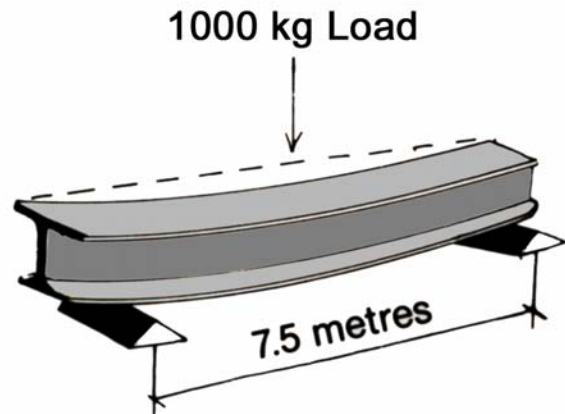

Instantaneous deflection = 1mm
Long term deflection = 1mm

310 x 165mm UNIVERSAL STEEL BEAM

The timber truss (See Figure 10c) will also deflect under the same load, but because it is braced by its triangular web layout, it is much stiffer than the heavier Oregon beam, and is nearly as stiff as a large steel beam which would weigh approximately three times more, and would probably cost five times as much as the timber truss.

Figure 10c

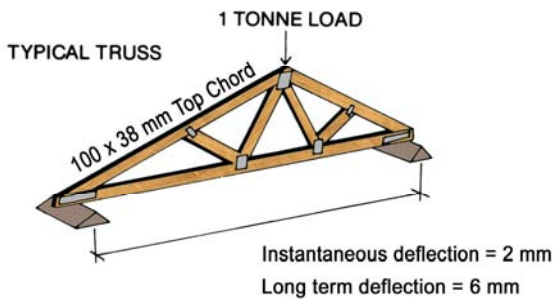

From these examples, it can be readily appreciated that timber trusses are very effective structural components.

Camber

To compensate for deflection which occurs when loaded, trusses are manufactured with an upward bow which is called “camber”. Some deflection occurs as the truss is erected, more deflection will occur as the roof and ceiling loads are applied to the truss, and further deflection will occur over a period of time due to the “creep”.

Because the chords are subjected to a distributed load, they will also deflect in between panel points, in addition to the truss as a unit deflecting downwards.

This deflection of the chords is called “panel deflection” and cannot be compensated for during manufacture, as can be for truss deflection (camber). All standard truss layouts, are designed to keep panel deflection within acceptable limits.

Figure 11

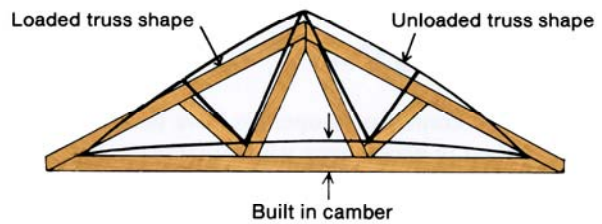

Trusses are cambered so that bottom chord becomes straight after a period of approximately 2 years

Figure 12

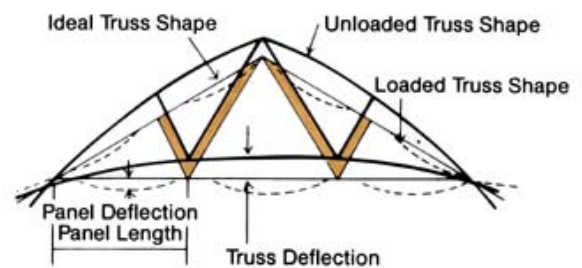

Exaggerated long term truss deformation under distributed top and bottom chord loads.

Truss Analysis and Member Design

When the design loads are known and a truss shape has been chosen, the truss can be analysed to find the forces that will occur in each of its individual members. This process is done by computer using well-established methods of structural mechanics. The computer uses a process of analysis that is integrated with the selection of members of suitable size and stress grade and the calculation of expected deflection when loaded.

Truss members are subjected to combinations of bending, shear and compression or tension. The combinations can vary during the life of the structure as different loading conditions occur and every foreseeable situation has to be considered. Timber members are chosen so that they meet the strength and serviceability requirements of AS 1720.1 ‘Timber Structures Part 1 - Design Methods’ for each load case.

GANG-NAIL CONNECTORS - HOW THEY WORK

A Gang-Nail connector is a steel plate with a collection of spikes or nails projecting from one face. The spikes, or teeth, are formed by punching slots in steel but leaving one end of the 'plug' connected to the sheet. The teeth are then formed so they project at right angles to the plate. During this process the teeth are shaped to produce a rigid projection. When the teeth of a connector plate are pressed into timber laid end-to-end, the plate 'welds' them together by forming a Gang-Nail joint. Connectors are always used in pairs with identical plates pressed into both faces of the joint.

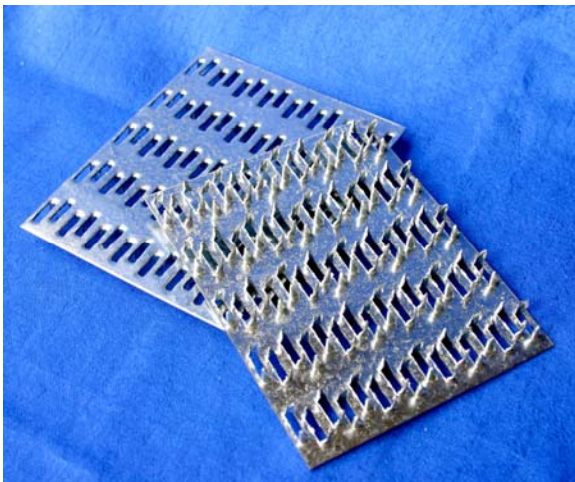

The concept is simple but the design of efficient Gang-Nail connectors requires careful balancing of tooth shape and density, connector plate thickness and ductility. An ongoing commitment to research and development ensures that MiTek's licensed truss fabricators have the most efficient truss system at their disposal.

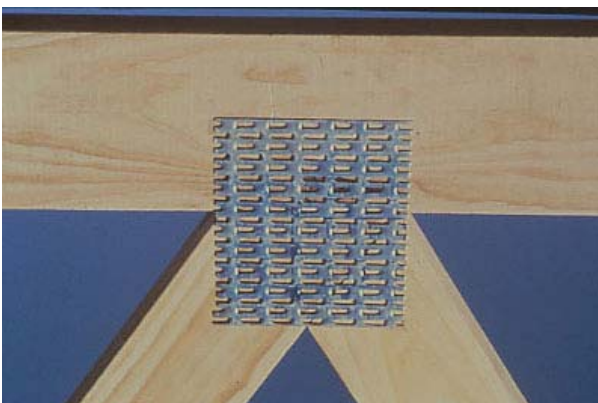

Performance criteria for Gang-Nail connectors

It is not economical to have a single connector that gives optimum performance under all loading conditions, for all of Australia's wide range of commercial timbers. MiTek Australia Ltd. has developed a complementary range of connector plates of varying plate thickness (gauge), tooth layout and tooth profile. These are:

GQ – 20 gauge (1.0 mm thick) galvanised steel. General purpose connector. Many short, sharp teeth - 128 teeth in a 100 mm x 100 mm area.

GE - 18 gauge (1.2mm thick) galvanized steel. Similar to GQ. For use when additional steel strength is required.

G8S – 18 gauge (1.2 mm thick) stainless steel. This connector is only used when the environment is highly corrosive. 70 teeth in a 100 mm x 100 mm area.

GS – 16 gauge (1.6 mm thick) galvanised steel. Heavy duty connector. 144 teeth in a 100 mm x 190 mm area.

Engineering Data

Gang-Nail connector properties have been established in accordance with Australian Standard AS1649 'Timber - methods of test for mechanical fasteners and connectors - Basic working loads and characteristic strengths. As well as testing new plate designs, MiTek Australia Ltd. conducts regular tests on their existing connector range and monitors the long term behaviour of joints subjected to constant loading. The CSIRO Division of Forest Products and the NSW Forestry Commission Division of Wood Technology have also done considerable research work on toothed metal plate connectors.

Full scale truss testing programs have also been carried out at the Universities of Western Australia and Adelaide, Australian National University and the Cyclone Testing Station at Capricornia Institute of Advanced Education.

ROOF TRUSS SYSTEM

Advantages of Roof Trusses

Gang-Nail trusses are an economical construction method for all types of roofs. The Gang-Nail System also allows solutions to many problems associated with complex roofs.

Design Flexibility

In domestic construction only the perimeter walls need to be designed as load-bearing walls when roof trusses are used. Internal walls become simple partitions and can be arranged without the need to provide supports for propping beams, hanging beams, etc. The sub-floor structure is simplified as stumps and bearers don't need to be arranged under internal non load-bearing walls and where concrete slab floors are used, the arrangement of internal beams is simplified.

Strength

Trusses are designed to engineering standards with a substantial factor of safety applying to every truss in the roof. Traditional 'stick built' roofs are based on historical carpentry practices, which are conservative, and so they use much greater quantities of timber to achieve acceptable factors of safety. The strength reserve of these traditional roofs and their supporting walls is also variable and depends on the skill of the individual carpenter.

Truss roofs can be designed to resist uplift due to wind suction and can be tied down to the supporting frame with greater security than is easily obtained with traditional roofs.

Project Management

Trusses shorten the construction time. With trusses, most roofs can be installed in one working day. Delivery and erection can be coordinated with the completion of the frame. Site labour requirements are reduced, as is the impact of wet weather on the construction program. Because trusses are manufactured specifically for each project, costly pilfering is virtually eliminated.

Building Permits

The Gang-Nail Truss System is a proven method of construction and is accepted by all building authorities. The MiTek network of licensed fabricators manufacture trusses in accordance with MiTek specification and design criteria. MiTek licensed fabricators can supply the necessary documentation for building permits.

Roof Layouts

Gang-Nail roof trusses allow just about any shape of roof to be constructed. However, there are a number of standard roof types that remain popular for domestic construction:

- Gable roof
- Hip roof
- Dutch hip roof
- Bell roof.

These terms refer to the shape of the roof cross section, and the detailing of the ends. All these roof types can be constructed in 'L' shapes, 'T' shapes and combinations of these with trusses of varying spans.

With trussed roof construction, only external walls are load bearing, making the design of floor structure simple and inexpensive.

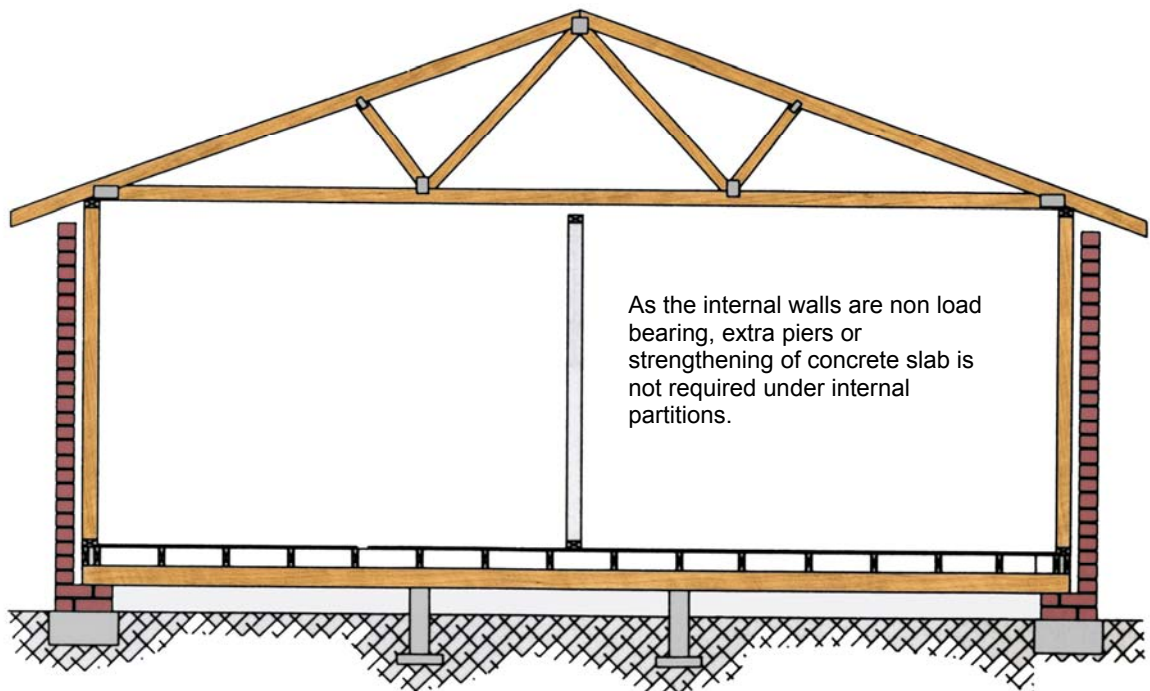

As the internal walls are non load bearing, extra piers or strengthening of concrete slab is not required under internal partitions.

Gable Roof

The simplest roof shape is a Gable Roof with two roof surfaces of equal pitch meeting at a ridge along the middle of the building.

The ridge runs the full length of the roof and the end walls run up to the underside of the roofing. With a simple gable roof only one truss shape is required.

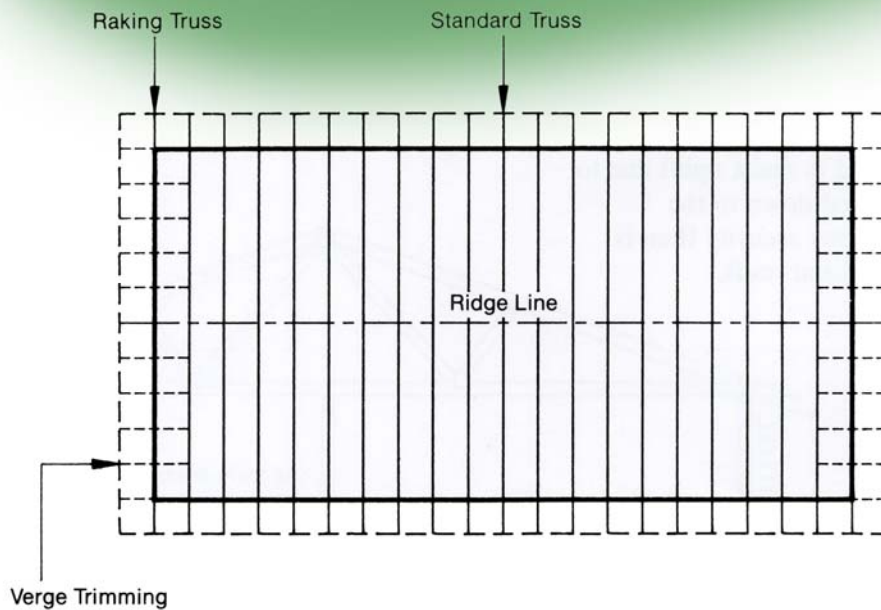
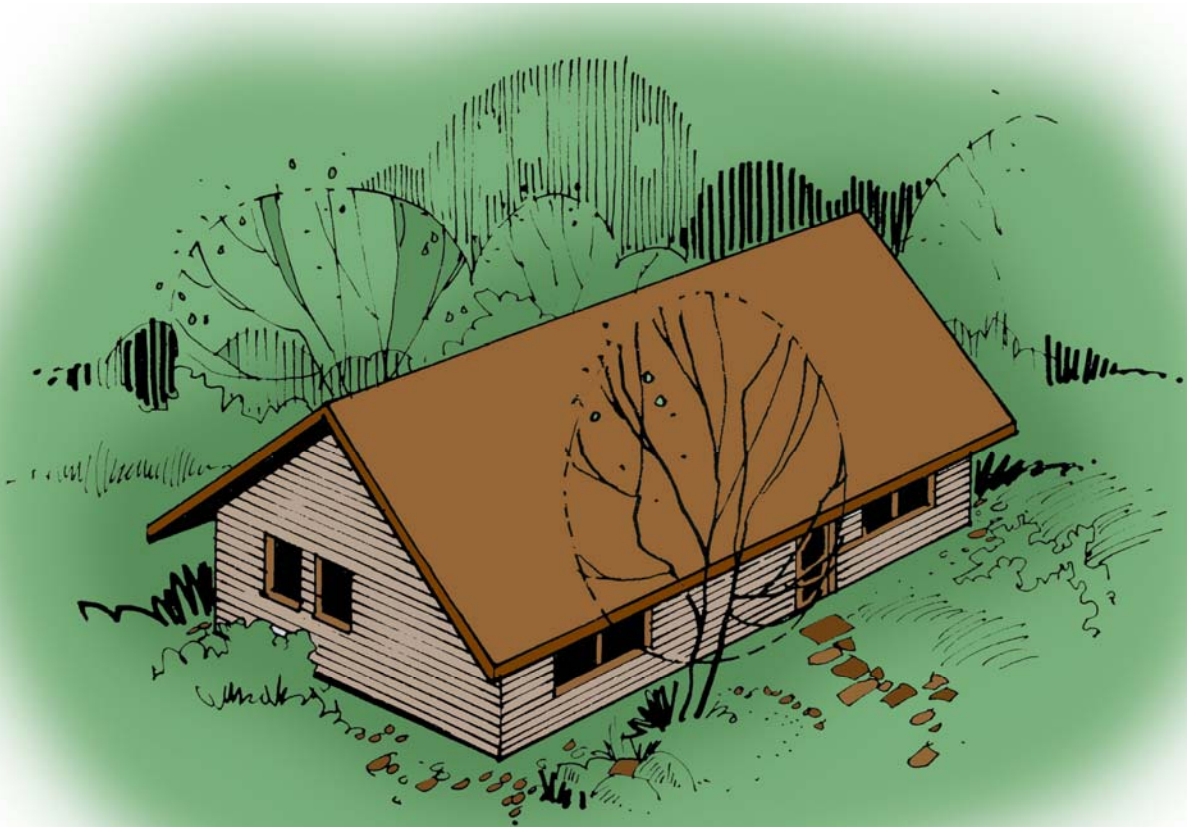

Hip Roof

Hip roofs are a very popular roof shape and can be readily constructed using Gang-Nail trusses. A hip runs up from each corner of the roof to the ridge and a special truss, called a truncated girder truss, is placed between the end wall and the apex of the roof.

The Truncated Girder Truss supports the jack and hip trusses that form the hip end framing. This truss derives its name from the shape and because it supports other trusses.

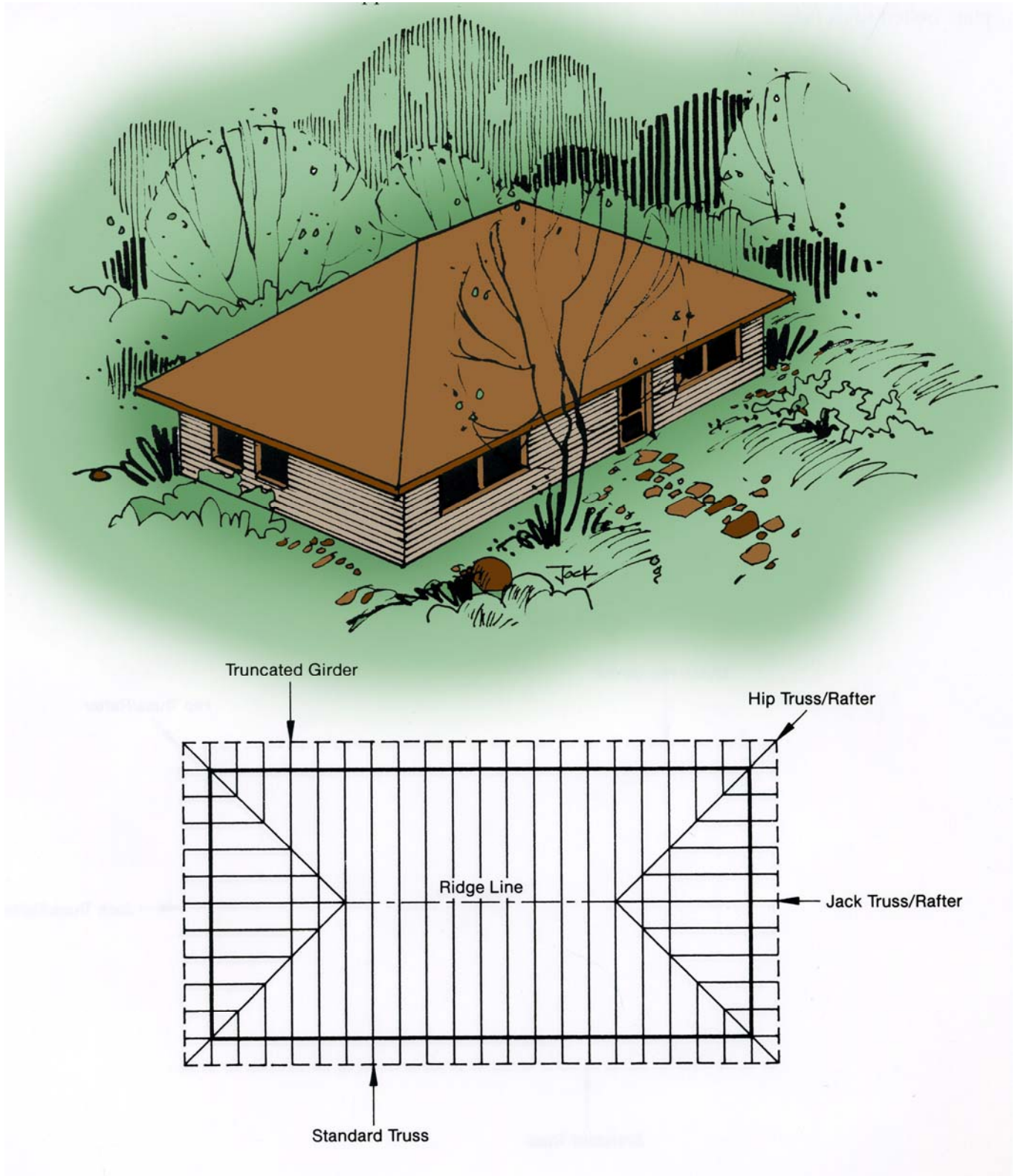

Dutch Hip Roof

A Dutch hip roof is similar to a hip roof except that there is a small gable located between the end of the building and the normal apex of the hip end near the end of the ridge.

In the case of the Dutch hip roof, the girder truss is a gable truss, and the hip and jack trusses are supported on a waling plate bolted to its face.

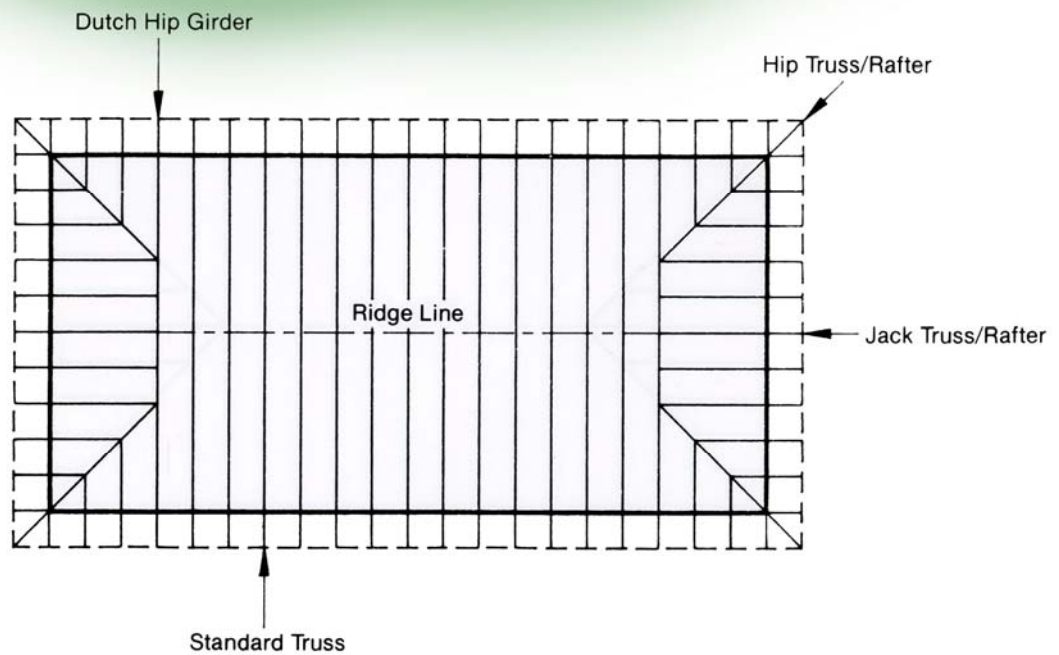

Bell Roof

A bell roof has two different pitches on each half and is often used on Australian colonial style buildings where it is common to have a high pitched roof with a lower pitched veranda section around the perimeter.

With trussed bell roofs, it is not necessary to have a support beneath the change in pitch as is required in the traditional construction. Bell roofs can have gable ends, hip ends or Dutch gable ends.

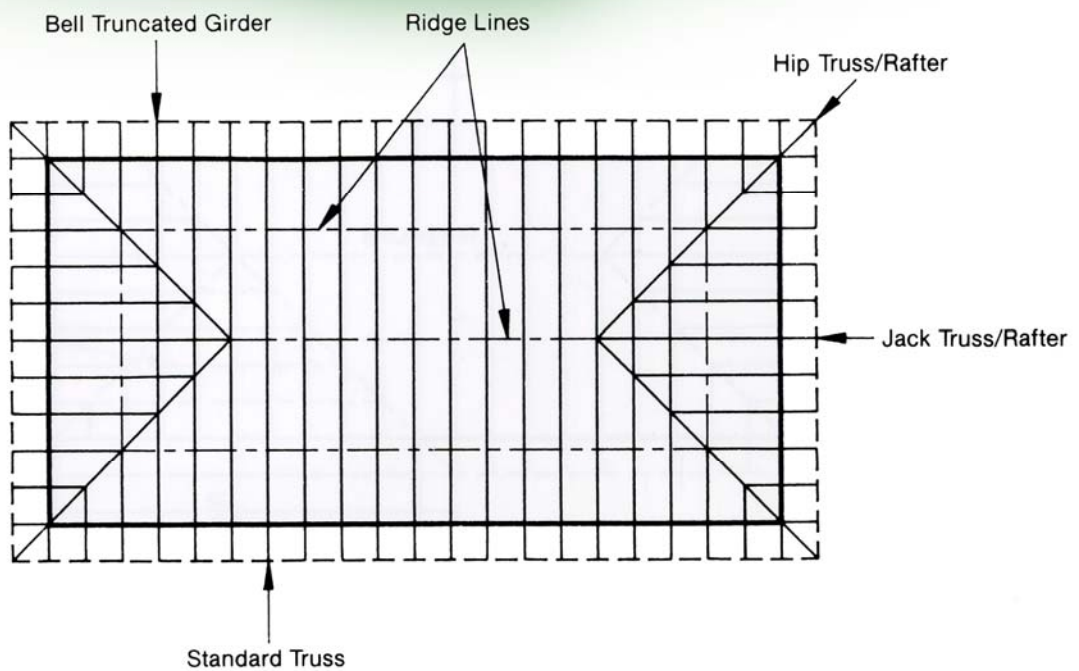
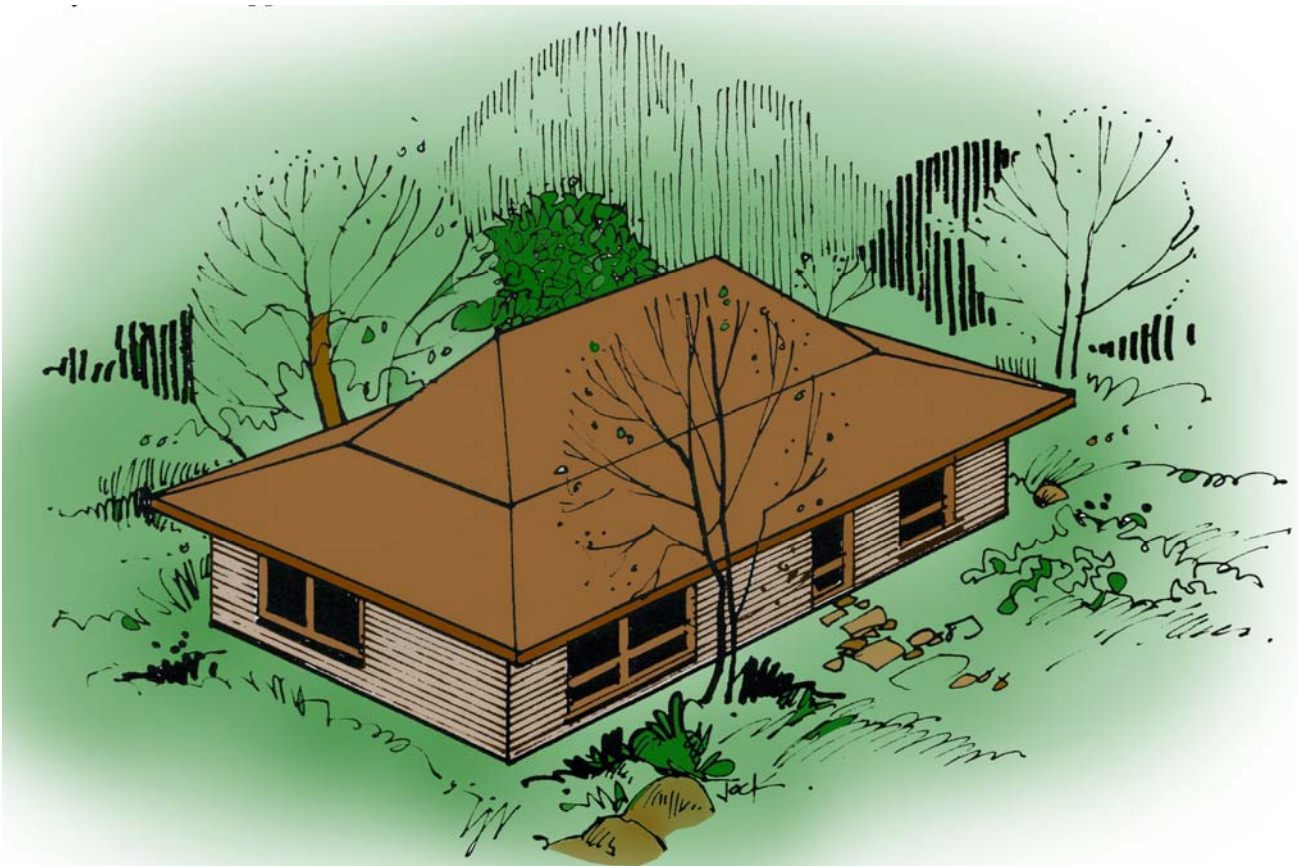

‘L’ and ‘T’ Shaped Roofs

Where floor plans are arranged in ‘L’ or ‘T’ shapes some trusses may need to be supported by other trusses. The supporting truss is called a girder truss, and it is usual to place the girder over the shortest span.

This truss is designed to act as a section of supporting wall or lintel, but one that is hidden above the ceiling. Girder brackets are bolted along its specially strengthened bottom chord and these support the ends of the standard trusses.

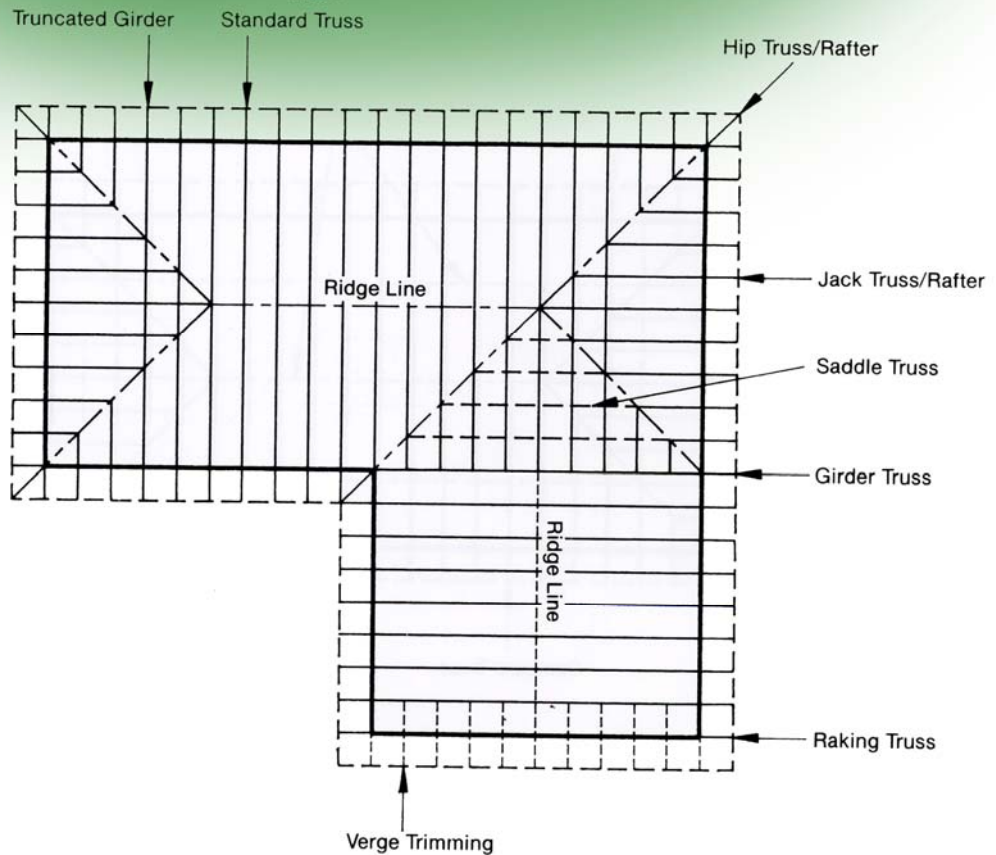

Framing is required above the standard trusses to support the roofing batten and special trusses called 'saddle trusses' are fixed on top of the standard truss top chords.

These saddles are really little frames and are usually made without diagonal webs as there is no requirement for them to act structurally as trusses.

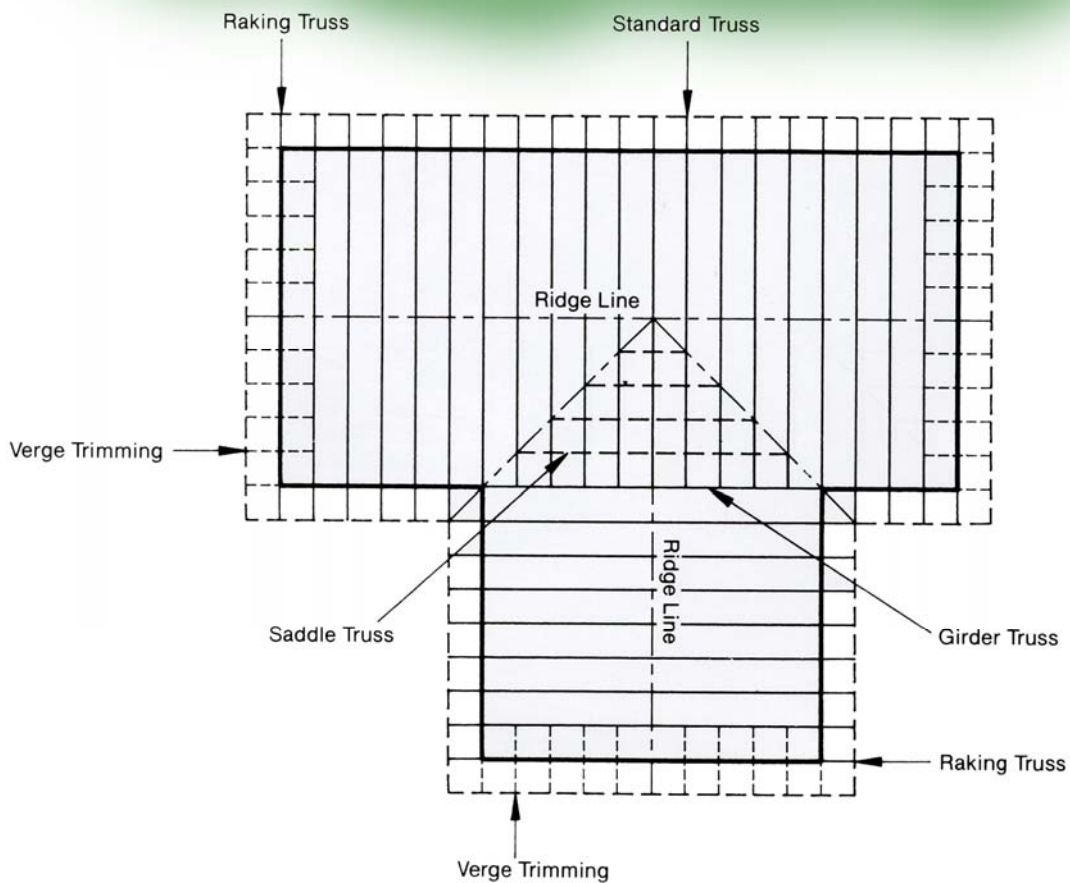
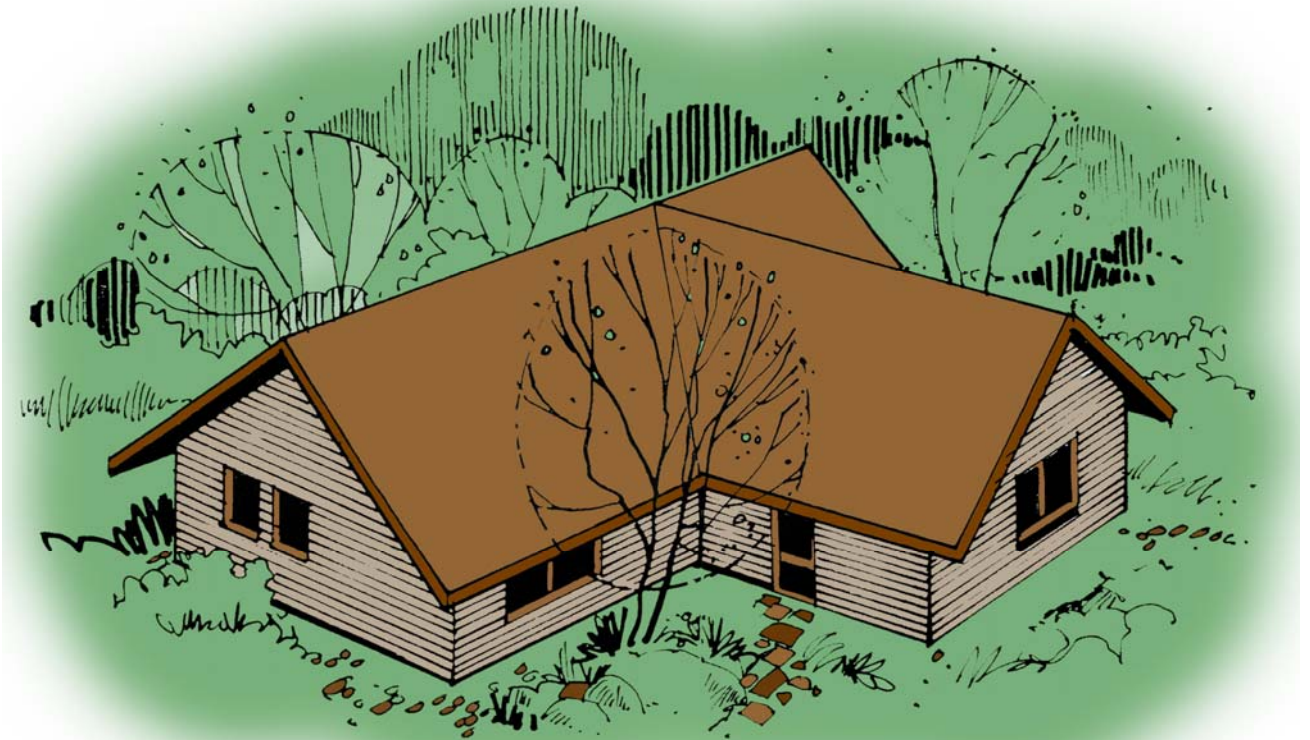

MANUFACTURING SPECIFICATION

Design

Gang-Nail Trusses are to be designed in accordance with the AS1720.1 - 1997 Timber Structures Part 1: Design Methods, and the joints are to be designed using the methods and design criteria supplied by MiTek Australia Ltd.

The Engineering drawings and/or data should specify member sizes and grades, permissible timber undersize, Gang-Nail connector sizes, locations and orientations at each joint, and truss camber if required. Web cutting details must be defined where the connector contact area will be effected.

Joint details, including chord and web cuts, connector plate size, location and orientation are to be as specified on MiTek20/20, DataTRUSS & RoofFAB outputs, unless other wise detailed on engineering drawings.

Connectors

All connectors to be patented "Gang-Nail" as manufactured by MiTek Australia Ltd.

Steel used for the manufacture of connectors will be Galvanized Coil to AS1397.

Zinc coating class to be Z275 on connectors where normal conditions prevail. Stainless Steel connectors are available for additional protection where trusses may be subjected to corrosive conditions, or where treated timber is used.

Timber

All timber used for truss purposes shall be visually or mechanically stress graded to the appropriate Australian Standard Specification. Refer AS1720 AS1720.1 - 1997 Timber Structures Part 1: Design Methods.

The strength, grade and size of each member in the truss shall comply with MiTek Software designs or engineering drawings, or be a higher grade. Truss members must not be substituted with wider timber if by doing so, the contact area of Gang-Nail connectors into other members will be reduced.

Timber must be of at least the specified nominal size, less any undersize specified by the designer. However, in no case should the difference in thickness of any two members meeting at a joint exceed 1.5mm.

In addition to the requirement of the Australian Standard Grading Rules, the following requirements apply:

- Sloping grain should be avoided in trusses manufactured from green timber, particularly in the top chord panel of gable trusses adjacent to the heel joint.
- Brittle heart in hardwoods should be excluded. Pith is permitted in timber subject to compliance with current visual and mechanical grading rules. Trusses manufactured using "pith included" pine shall be designed for joint Group JD5 timber to make allowance for the reduced tooth shear capacity of this timber.
- Loose knots shall be avoided under Gang-Nail connectors. Sound, tight knots are permitted at joints provided they comply with the relevant structural grading rules for the timber grade specified.
- Untreated Lyctus susceptible sapwood is not permissible under a "Gang-Nail" connector.

Where significant spring is present in a truss chord, the member should be sawn such that the spring best conforms to the camber being set into the truss.

Fabrication

Trusses are to be fabricated on jigs approved by MiTek Australia Ltd., and capable of ensuring uniformity of truss shape.

Pressing equipment must be capable of pressing connectors into timber without damage to the connector or the timber.

Gang-Nail connectors shall be pressed home so that the sum of the gaps on either side of the joint does not exceed 1.5mm.

The maximum gap between any two adjacent members at a joint is 2mm.

Trusses are to be strapped into packs of five or more to improve stability during handling. Packing or other suitable protection should be used under straps to avoid damage to the outer members. Trusses must always be handled so as to avoid excessive lateral bending. Any truss which incurs set after such bending should be rejected.

The fabricator shall clearly label each truss showing its "mark", and identify internal support points if applicable.

Camber as specified by the designer is to be achieved with a maximum tolerance of 3mm.

IMPORTANT NOTES

Where large cambers are required, e.g. 15mm or more, it is the building designer's responsibility to ensure that this camber will not create difficulties for finishing grades or cause damage to cladding material. Instead, special designs with internal supports should be considered as a means of reducing camber.

All cambers shown for green timber assume a timber moisture content of approximately 70%, and hence a creep factor of 3. For immediate moisture contents toward the dry condition of approximately 15%, a reduction in camber should be made appropriate to the creep factors of 3 and 2 which apply for *green* and *dry* timber respectively.

For trusses manufactured from green timber and supporting metal deck roofs, the recommendations given in MiTek software designs may be over estimated. *Shrinkage* of the top chord may be effectively restrained by modern fixing techniques and the use of long continuous sheet lengths. As the majority of calculated truss camber is caused by reduction of top chord length, the recommended cambers may be reduced by approximately 50% in such cases.

For sheet roofs incorporating well fixed and continuous material, even further reduction of recommended camber should be considered where the slope of the roof is conducive to *arching* or *shell* action.

ORDERING TRUSSES

All relevant details including building plans, specifications and loadings should be provided to the truss fabricator prior to ordering trusses. This will ensure the roof truss system is designed, manufactured and installed to suit specific job requirements.

Wind load is an important factor in the design and performance of roof trusses. Ensure that you have correctly advised the truss fabricator with regard to wind load requirements, and that adequate provision has been made to fix trusses to support structure to withstand wind uplift forces.

The effect of wind on a roof is predominantly uplift forces. The degree of uplift varies and is dependent on a number of factors including design wind velocity, roof pitch, building shape, roof and ceiling material, and degree of venting to ridge and eaves.

When specifying design wind velocities for a particular project, the following minimum information should be provided:

- Regional Basic Design Wind Velocity - this is the town, city or area where the project is used for housing.
- Mean Return Period - is dependent on the type of building, e.g. farm, domestic or hospital. Normally a 50 year return is used for housing.
- Geographical Location - some areas such as cyclonic prone areas requires special consideration.
- Terrain Category - is an allowance for the type of terrain in the immediate vicinity of the project.
- Shielding - in some cases a reduction in design wind velocity can be made by use of surrounding buildings and landscape.
- Height Above Ground - generally wind loads increase with height above ground level.

Trusses are designed for normal roof, ceiling and wind loads to suite specific jobs and conditions. Additional loading such as solar units, hot water tanks, air conditioning, etc. require special consideration. Advice should be sought from a fabricator prior to commencing construction.

Wall frames and beams supporting trusses must be designed for the correct roof loads. Refer to AS1684-1999 Residential Timber Framed Construction for details.

Trusses are generally designed to be supported on the outer wall with inner walls being non load bearing. Where it is necessary to use internal walls for load bearing, these walls will be clearly shown on layouts.

For environments where the atmosphere may be conducive to corrosion, such as some types of industrial and agricultural buildings, or building near the ocean and subject to salt spray, consideration should be given to the use of G8S stainless steel connector plates.

Trusses are designed for specific loading, geometry and support conditions. Under no circumstances should truss timber be cut, removed or trusses be modified in any way without prior approval from the truss fabricator.

Make sure all bracing is permanently fixed and all bolts and brackets are tightened prior to the loading of the roof.

TRANSPORT, STORAGE & LIFTING

Transport & Job Storage

Trusses shall be fully supported when being transported in either the horizontal or vertical plane. Care must be taken when tying down not to damage chords or webs.

On their delivery to site, trusses shall be inspected by the builder or his representative. Any shortages or damaged trusses shall be reported to the fabricator immediately. Damaged trusses shall not be site-repaired without prior approval from the truss fabricator.

Where it is anticipated that trusses will be stored on site for an extended period of time before use, adequate provision should be made to protect them against the effects of weather. Trusses manufactured from seasoned timber should be covered to avoid wetting and protective covers where used, should allow free air circulation.

When stored on the job site, trusses shall be on timber billets clear of the ground and in a flat position to avoid distortion.

Lifting

When lifting, care must be taken to avoid damaging of joints and timber. Spreader bars with attachment to the panel point should be used where span exceeds 9000 mm. Never lift by the apex joint only.

The trusses may also be placed on the top plates by pulling them up skids, spread at 3000 mm, taking the same precaution as described above. Ensure that the trusses are not distorted or allowed to sag between supports.

The recommended method of lifting trusses will depend on a number of factors, including truss length and shape.

In general, sling truss from top chord panel points as shown below. Slings should be located at equal distance from truss centreline and be approximately 1/3 to 1/2 truss length apart

The angle between sling legs should be 60° or less and where truss spans are greater than 9000 mm a spreader bar or strong back should be used. Some typical examples are shown below.

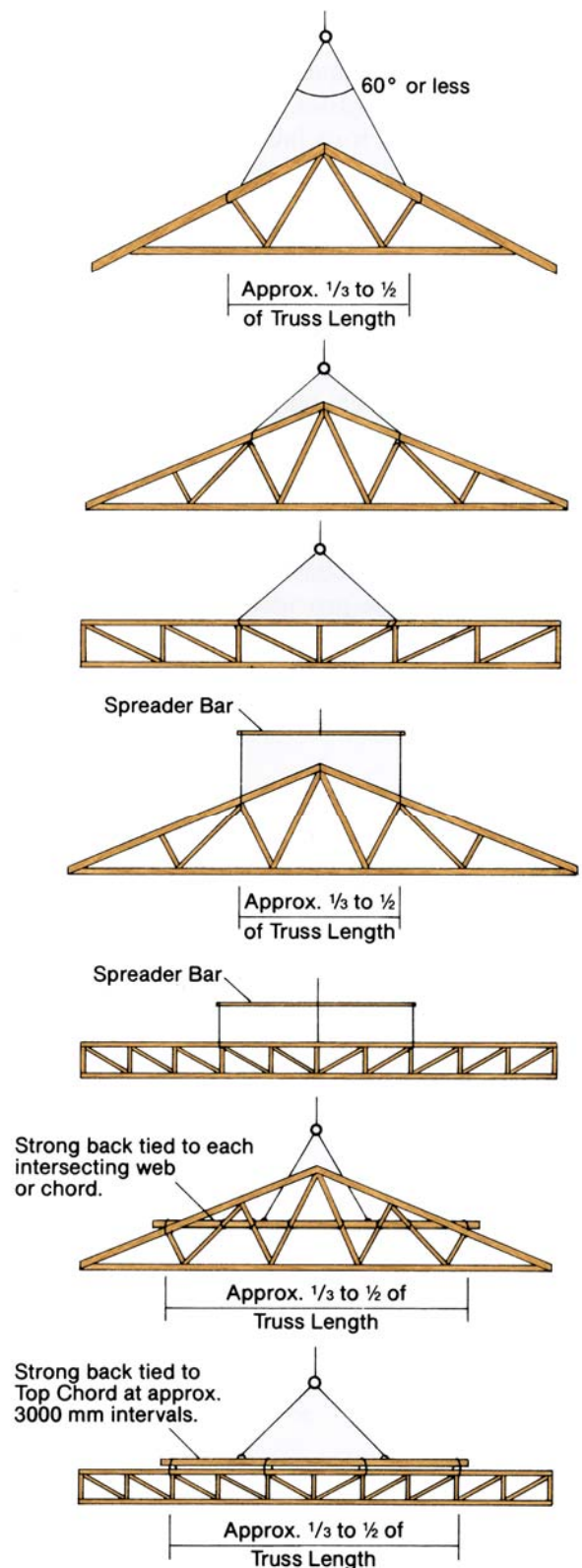

SUPPORTING STRUCTURE

Footings and sub-structure supporting trussed roofs should be designed with the additional loads on the external walls taken into account. Unless otherwise noted, truss designs assume the supporting structure is adequate to resist all horizontal and vertical loads. Where wall construction does not comply with local building regulations, a special design should be carried out by the building designer.

Footings should be in accordance with local building regulations. Where large concentrated loads occur such as supports for girder trusses, a special check should be made by the building designer.

Sizes of studs, bearers and external walls should be in accordance with AS1684 -1999 "Residential Timber Framed Construction", or as specified by local building regulations. Where large concentrated loads such as those due to girder trusses occur, a special design check should be made by the building designer.

Trusses should ideally be positioned directly over wall studs at the centres specified on the drawings. Where this is not possible, wall plate sizes shall be as given in AS1684 -1999 "Residential Timber Framed Construction", or in accordance with local building regulations.

Lintel sizes and support details shall be a minimum of those given by AS1684 -1999 "Residential Timber Framed Construction". Attention is also drawn to the lintel size charts published by MiTek Australia Ltd.

INSTALLATION

Trusses should be handled and installed in such a way as to avoid damage and permanent sets. To this end, truss installation bracing and truss fixing details, should comply with recommendations given in MiTek's "Fixing and Bracing Guidelines for Timber Roof Trusses" publication.

Trusses should be installed in line with the intentions of the designer. Truss centres, cladding material and design wind velocities should all be in accordance with the truss design data given on relevant design drawings or MiTek Software output. Roof layouts should comply with the drawings (where thereon indicated) and in no case shall the trusses be at greater centres than specified by designs.

Temporary bracing (MiTek Truss Spacers) shall be provided during installation to hold trusses plumb and stable and should not be removed until permanent bracing purlins and battens have been attached. Temporary bracing should be in accordance with drawings (where thereon indicated) or in accordance with the MiTek "Fixing and Bracing Guidelines for Timber Roof Trusses".

Permanent bracing shall be in accordance with recommendations given in MiTek's "Fixing and Bracing Guidelines for Timber Roof Trusses", or in accordance with relevant drawings. In all cases, permanent bracing shall comply with requirements of local building regulations.

Alterations or modifications to trusses of any sort (including cutting, checking, etc.) shall not be made. Consult the Design Engineer.

Fixing of trusses to the support structure should be adequate to withstand all vertical and horizontal forces given by truss designs. Suggested fixing methods are given in MiTek publications, including the "Fixing and Bracing Guidelines for Timber Roof Trusses". These details should be used as a guide only, as it is the building designer's responsibility to determine the fixing requirements necessary to suit the overall building design, and to provide adequate bearing and hold-down for trusses.

INSTALLATION cont'd

Trusses shall be supported on external load bearing walls only unless otherwise specified by the designer. Special provision shall be made to ensure significant vertical loads are not transferred between truss and non-load bearing walls. To this end, load bearing walls should be a minimum of 12 mm higher than non-load bearing walls. Attention is drawn to the recommendations given in MiTek “Fixing and Bracing Guidelines for Timber Roof Trusses”.

Roof and ceiling battens should be at centres specified by design and be sized and fixed in accordance with codes and/or manufacturer’s recommendations. Refer to MiTek “Fixing and Bracing Guidelines for Timber Roof Trusses” for further details

Longitudinal ties, where required, should be sized and fixed to web or chord in accordance with MiTek “Fixing and Bracing Guidelines for Timber Roof Trusses” or as specified on design drawings.

Roof trusses shall not be subjected to loads other than the following, unless noted otherwise on drawings.

Loads imposed by components of the roof such as those due to roof cladding, member self weight, etc. as set out in AS 1170-Part 1 “LOADING CODE, Dead and Live Loads and Load Combinations”.

Loads applied for short duration, such as roof live loads encountered during installation and maintenance operations as set out in AS 1170-Part 1 “LOADING CODE, Dead and Live Loads and Load Combinations”.

Trusses supporting loads from services such as hot water and air conditioning units shall be designed specifically for these additional loads. Units, where installed, shall not impose heavier loads or be located at positions other than those indicated by design. In no case shall trusses be cut or modified to accommodate units or ducts.

Roof material should be fixed to trusses within one or two weeks after installation to provide protection against the weather. Prolonged exposure to rain and sun should be avoided as repeated wetting and drying has a detrimental effect on the strength of both timber and connection.

BRACING

Roof trusses will support their design loads when they are:

- installed in a vertical position,
- supported at the designed bearing points,
- braced to prevent over turning,
- braced to prevent sideways buckling,
- tied down to support to prevent uplift,
- undamaged during handling and erection.

Trusses, particularly large spans, need to be handled with care. The incorrect location of lifting slings can cause trusses to buckle under their own weight. With long, low pitch trusses, lifting spreaders or strongbacks may be required.

Permanent Roof Bracing

When trusses are designed, a truss layout of the roof is prepared. This will be supplied by the truss fabricator along with the MiTek “Fixing and Bracing Guidelines for Timber Roof Trusses” booklet either at the time of placing the order or with the delivery of the trusses. This layout will specify the location of each truss and bracing, and will note any special requirements.

MiTek “Fixing and Bracing Guidelines for Timber Roof Trusses” booklet gives detailed instructions on erection procedure and fixing of bracing.

PosiSTRUT Flat Chord Truss System

What is PosiSTRUT?

The PosiSTRUT truss is perhaps best described as an open web joist for a parallel corded truss, however, it is not simply an open web joist. The PosiSTRUT truss has special attributes which make it stand apart from the rest. Essentially it is a hybrid truss incorporating the versatility of timber and the strength of steel.

Unlike the conventional timber truss, the timber cords on the PosiSTRUT truss are on flat with a broad surface horizontal. This makes the PosiSTRUT truss much stronger and more rigid than conventional timber trusses. Its wide surface also makes fixing of flooring easier as it provides ample width to join floor sheeting during installation and renders the truss more stable.

In many respects it is similar to the I-Beam. The cords can be compared to the I-Beam flanges and the PosiSTRUT to the web. Structurally the "I" section is a very efficient shape because it concentrates the bulk of the material to the outer edges. This is also true of the PosiSTRUT truss and is a major reason why it performs better than the conventional timber truss. The steel web is the heart of the PosiSTRUT system. Shaped like a boomerang it has the well proven integral Gang-Nail teeth which provide a very strong, reliable connection.

Advantages

Posi-STRUT Floor trusses offer the following advantages over solid beams:

- Plumbing, electrical conduit and ducting can be run between chords and webs.
- No drilling or notching required to accommodate services.
- Additional width available for fixing flooring.
- Ceiling material can be fixed directly to the truss bottom chords.
- Greater spans can be achieved with floor trusses than with solid timber joists, creating large open areas.
- Internal load bearing walls to stumps and bearers can be reduced or eliminated.
- Shrinkage problems sometimes encountered by green hardwood joists can be reduced or eliminated.
- Lightweight and easy to handle.

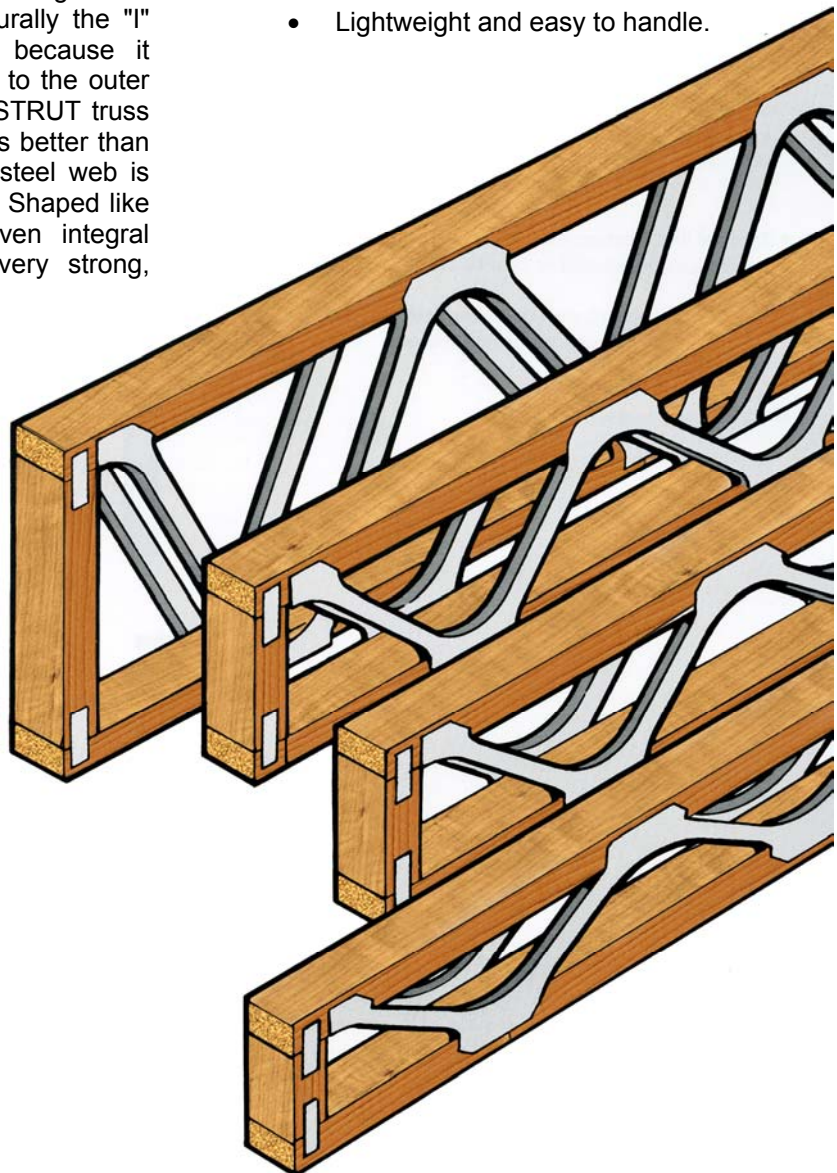

How is PosiSTRUT used?

Floor construction is the major area of PosiSTRUT's application. Wherever floors require clear spans of four to eight metres, the PosiSTRUT truss will provide an economical solution. Whenever dealing with second storey design, steeply sloping sites or poor foundation conditions, PosiSTRUT trusses should be considered. PosiSTRUT is also ideally suited to commercial floors which usually require larger spans than domestic floors and heavier imposed live loads, in fact the greater the span and depth of the truss the more competitive PosiSTRUT becomes.

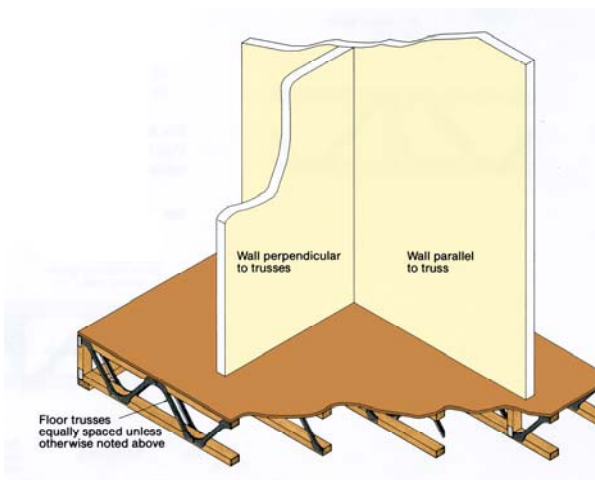

PosiSTRUT trusses also provide an ideal solution for large span rafters, particularly where they support tiled roofing and/or ceilings which require support members with close spacing. PosiSTRUT trusses can be economically used at 600 or 900 centres. This allows conventionally sized tile battens or ceiling battens to be used without secondary members. PosiSTRUT can also be used to advantage in the construction of portal frames for large agricultural buildings. PosiSTRUT purlins on steel portal frame buildings offer an excellent alternative to cold-formed steel sections. They are light, easily handled, easy to fix, custom made, stable and easily braced.

Why should you use PosiSTRUT?

PosiSTRUT trusses are easy to handle due to their light weight. Weighing approximately 5.5kg per metre, they are significantly lighter than a 300 x 50mm Oregon beam which weighs 11kg per metre. Sub-contractors who have used PosiSTRUT trusses insist that they are easier to lift and therefore install. PosiSTRUT is also renowned for its stability. It will stand upright, does not require temporary bracing and will not buckle sideways as slender beams or joists have a tendency to do.

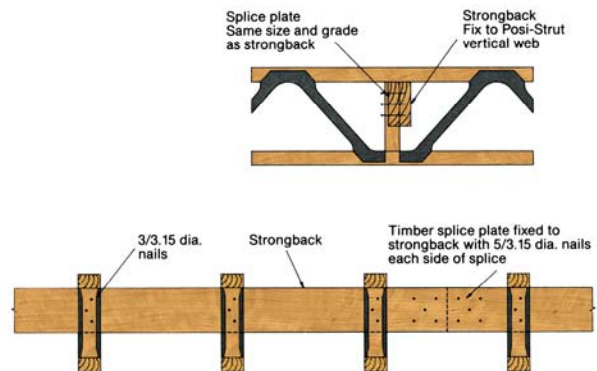

PosiSTRUT trusses are convenient to install, no herring-bone bracing or solid blocking is necessary. A simple strongback which is nailed to the timber vertical web at 2500 centres is all that is required. The strongback bracing which is unique to the PosiSTRUT system, reduces the bounce commonly found in long-spanned floors by distributing dynamic loads to adjacent trusses. The use of strongbacks virtually eliminates the problem of squeaking floors by reducing the relative movement in adjacent trusses.

PosiSTRUT trusses have a wide surface – which makes it easier to fix flooring. It also enables the joining of panel flooring without the need to double up or pack joists. No temporary bracing is required with PosiSTRUT; it can simply be placed into position.

PosiSTRUT trusses are custom made; which eliminates the need for cutting or docking on site. Using MiTek's 20/20 computer program, the floor structure is automatically laid out and the trusses engineered taking into account internal supports and special loading conditions. This makes the PosiSTRUT a truly customised engineered floor system.

PosiSTRUT trusses are then fabricated in precision jigs that ensures they are straight and true. If required, they can have a nominal amount of camber built in. As PosiSTRUT trusses are fabricated from kiln dried timber, they are also uniform in depth. This not only provides a flat floor surface, but also means that no further work is required to achieve a flat ceiling. Because PosiSTRUT is an open web construction, large diameter air-conditioning ducts can be conveniently threaded through the trusses. It also permits plumbing in wet areas to be contained within the floor cavity.

PosiSTRUT is economical. Cost effectiveness is an important issue in any building project and PosiSTRUT will save you money in both materials and on-site labour. PosiSTRUT is manufactured in nominal sizes of 200, 250, 300 and 400 millimetres.

The PosiSTRUT concept is an innovative and efficient structural system which will provide an economical and practical solution to many building projects. PosiSTRUT's many attributes have made it the builders preferred choice for both floor and roof construction. PosiSTRUT has the answer to your specific building needs.

PosiJOIST & PosiPLUS

PosiJOIST and PosiPLUS have all of the unique characteristics of PosiSTRUTs open web construction, combined with the ability to trim the length on site. Their patented trimmable end panel now gives you all the benefits of PosiSTRUT trusses with the ability to make final adjustments to the span on site. Using a conventional power saw it is possible to trim the ends of the joist, enabling quick adjustment to span to an accuracy of 1mm. This can be achieved without cutting through the connector plate or end vertical webs. This feature makes PosiJOIST and PosiPLUS particularly useful where trusses are to be supported by angled or curved walls.

PosiJOIST and PosiPLUS mean that you can now obtain all the benefits of PosiSTRUT open web trusses with the fast delivery of an ex-stock product. PosiJOIST and PosiPLUS work for you through their unique flexibility in conjunction with a range of benefits offered by the PosiSTRUT system.

PosiSTRUT, PosiJOIST and PosiPLUS trusses represent the kinds of innovations which will set the standard in floor and roof construction for the future.



PosiJOIST



PosiPLUS

ConstructaBEAM

Wide planks of sawn timber have always been at a premium. They can only be cut from the largest and straightest sawlogs, and they can be easily spoiled by defects within the timber itself. With sawlogs harvested from plantation and regrowth forests, these larger sections are very difficult to obtain.

The Gang-Nail ConstructaBEAM System enables the manufacture of long lengths and large sections using short lengths of seasoned timber end to end to make long lengths, and edge-to-edge to form large sections. Beams up to 295 mm deep and 10m long can be manufactured using the ConstructaBEAM System.

Advantages and Applications

- ConstructaBEAMS can be used for floor joists, rafters, hanging beams and lintels, and they offer many advantages to the builder compared with traditional, unseasoned timber:
- Available in long lengths, 'made to order', and cut to your exact length.
- Dimensional stability.
- The consistent quality of an engineered product.
- High stress grade timber, as defects are removed before manufacture.
- Economical.

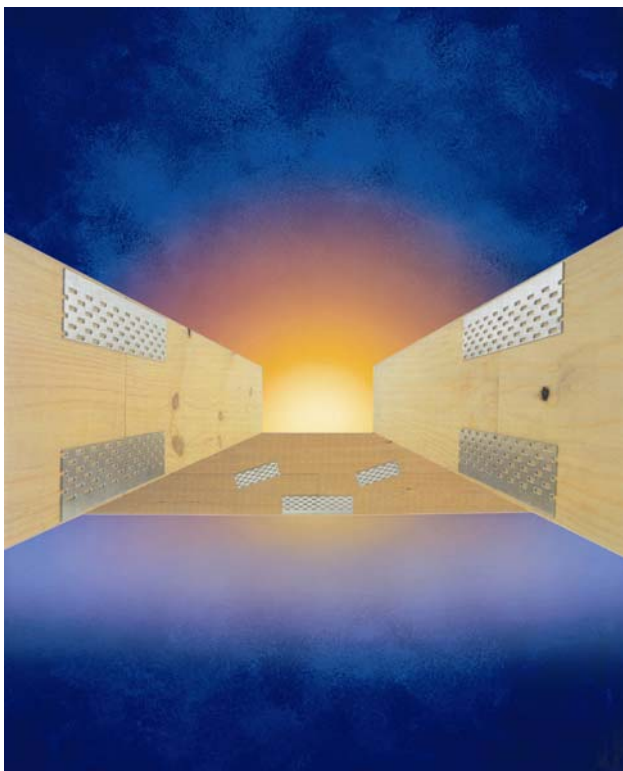

Long Lengths

ConstructaBEAMS can be made to order, to any length which can be transported and handled without damage. Rafters and joists can be continuous over internal supports, enabling smaller section ConstructaBEAMS to be used than would otherwise be required for a simple span.

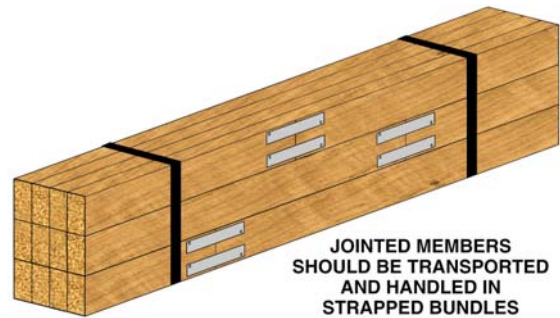

Dimensionally accurate and stable

Laminated ConstructaBEAMS are manufactured only from seasoned timber. They are dimensionally stable and will not shrink, warp, twist or split. Long term deflection is less than for unseasoned timber, and this often allows the use of smaller sections.

ConstructaBEAMS are accurately sawn, and time is not wasted levelling out the high and low spots which can occur with unseasoned joists and rafters.

The Gang-Nail Difference

ConstructaBEAM is an engineered product with the full support of the Gang-Nail System. This is a guarantee of performance which is simply not available with solid timber sections. The concept has been developed into a reliable production technology by MiTek Engineers. The product, ConstructaBEAM, has been subjected to exhaustive laboratory testing and has proven to be a very reliable product in practice. The development is ongoing in an endeavour to further improve the process.

High Stress Grade

The manufacturing process enables natural defects in the timber pieces to be cut out before they are incorporated into a ConstructaBEAM. The removal of defects has the effect of improving the grade of the timber being used, as the probability of knots or other defects occurring at critical locations is reduced.

Economical

The ConstructaBEAM process adds value to the beam components which may be random lengths, shorts, etc. and the resulting ConstructaBEAM fills the need for large section stable beams in long lengths. A need that traditional, solid timber is finding difficult to meet.

Design

The Gang-Nail System provides full technical support for ConstructaBEAMS, with span tables available for:

- Rafters
- Ceiling Joists
- Hanging Beams
- Lintels

Special designs can be prepared to suit unusual applications, non-standard beam sizes or uncommon timber grades.

Beams of the same depth and thickness may have different connector plates and these may be at different spacings along the beam depending on their intended application. For example, ConstructaBEAMS to be used as lintels will require heavier plates than would be needed for rafters. Special manufacturing specifications are required for each beam application and the intended End Use is always marked on the finished beam.

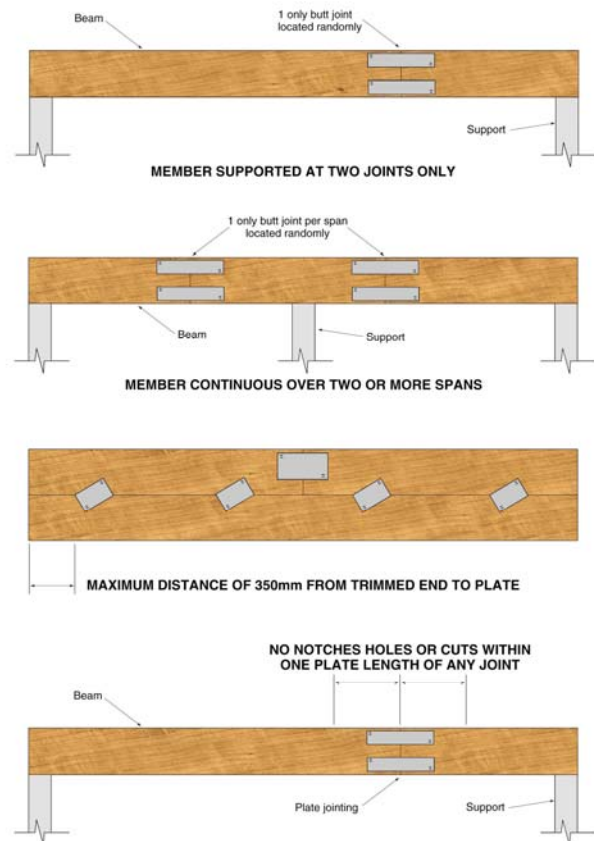

Manufacture

Because the pressing equipment required to manufacture ConstructaBEAMS is relatively simple, their production is not limited to the network of licensed MiTek truss fabricators. Timber merchants who install a ConstructaBEAM line find they are able to reduce their inventory, and at the same time improve the range of beams on offer to their clients.

Press operators are trained by MiTek personnel who must be satisfied that the press operators and the licensed merchant will maintain the reputation of both ConstructaBEAM and MiTek.

Installation

Laminated ConstructaBEAMS are not the same as solid timber. They can be docked to length only at specified locations, and in such a way that connectors are never more than 450 mm from the end of the beam.

Not all ConstructaBEAMS are the same. Lintels carry heavy shear loads; therefore, ConstructaBEAM lintels have heavier connector plates than those used on rafters, etc. End use is indicated on all ConstructaBEAMS, and only those marked "Lintel" should be used for that purpose. Double thickness beams should be nail-laminated to ensure that they share the imposed loads equally.